

# Industrial Products Source

ISSN 0973-1857

A Magazine for Indian Industries

Vol 21

Issue 4

April 2024

₹ 30/-

A Product News Publication

Total no. of pages 60

Visit: [www.ips.co.in](http://www.ips.co.in)  
to view our e-magazine

## Focus:

Pumps & Valves, Pneumatics & Hydraulics  
Chemical & Petrochemicals, Process Plant & Machinery

Products Index  
Page 54



## VIJAYALAXMI ENTERPRISES

High-Quality and Economical Solutions for EOT Crane Components



Rail Clamps



Thruster Brakes



Hyd. Thruster Brake



Resistance Box



Crane Limit Switches



Cable Trolley

Vijayalaxmi Enterprises is a Quality conscious unit established under able leadership of Mr. Narayan Kashid in 1982, who has more than 35 yrs experience in this heavy engg sector. We specialize in manufacturing Rail Clamps, Resistance Box, Cable Trolley, Limit Switches, Thruster Brake and Current Collectors. With an in-house test facility. We are one of the largest manufactures of above mention products.

Mr. Yogesh Kashid Mob: 90046 85089 / 79774 16311  
17/603, Regency Estate, Kalyan-Shil Road, Dombivali (East), Thane 421 203  
Web: [www.vijayalaxmienterprises.in](http://www.vijayalaxmienterprises.in) • E-mail: [info@vijayalaxmienterprises.in](mailto:info@vijayalaxmienterprises.in)

Dealership Enquiries Solicited



CHANNEL PARTNER FOR  
**SIEMENS**  
(Mumbai, Konkan)

Manufacturers of Level Instruments, Reflex  
Transparent Boiler Gauges, Sight Glasses  
Magnetic Level Indicators, Transmitters, Switches

Over 50 Years of Service  
to Process Industry



### Other Products:

- Reflex & Tubular Level Gauges
- Magnetic Level Indicators
- Level Switches & Transmitters
- Float & Board Level Indicators
- Manometers & Sight Glasses

## R. K. DUTT CONCERNS

AUTHORIZED CHANNEL PARTNER for  
SIEMENS Process Instruments.

Manufacturers of LEVEL, PRESSURE, FLOW Indicators.

A-88, Road No. 18, Wagle Estate, Thane 400 604, Maharashtra

Tel.: 022 - 6724 8787 / 2582 2541 • Fax: 022 - 6724 8777

E-mail: [marketing@rkdutt.com](mailto:marketing@rkdutt.com) • Website: [www.rkdutt.com](http://www.rkdutt.com)

our customize product range make us

**No.1**

IN SURFACE FINISHING SOLUTION



Spl. Shot Blasting M/c For Fold-away  
Tray of Sheet Molding Compound



Spl. Pressure Blaster M/c  
with Roller for Roll Etching



Spl. Blasting M/c for Cleaning  
of Submersible Pump Casing



Airless 4W Tunnel Type Blasting  
M/c for Sheet Blasting



PRESERVATION LINE  
In-line Blasting, Painting & Baking System



BLAST ROOM & PAINT ROOM SYSTEM  
Supplied For Rail Chassis Body



**MEC SHOT BLASTING  
EQUIPMENTS PVT. LTD.**

H.O. & Works: B-14, Parshvath Industrial Estate Yojna  
Khasra No. 160, Mogra Kalan, Tehsil - Luni  
JODHPUR - 342802 (Rajasthan) INDIA

ISO 9001 ISO 14001 CE

0291-2740609 | E-mail: [mail@mecshot.com](mailto:mail@mecshot.com) | Website: [www.mecshot.in](http://www.mecshot.in)



# EMPIRE CABLES

*Connecting Your Life*



## PRODUCT RANGE

- Power & Control Cables (Aluminium/Copper Conductor/Armoured Unarmoured Cables)
- FR / FRLS PVC Cables ( HT & LT Cables)
- House Wiring / Multicore
- Flexible / Industrial Cables
- Hook up Wires
- 3 Core Flat Submersible Cables
- Telecommunication Cables
- Co-axial / Instrumentation / Computer Cables
- Aerial Bunched Cables
- TRS / TRS Braided / Welding Cables
- CCTV / Cat-5 / LAN Cables
- Solar Cables
- Moulded Plugs
- All Kinds of Other Special Cables



Mfg. by :

**EMPIRE CABLE INDUSTRIES PVT. LTD.**

115, Badli Industrial Area, Phase-2, New Delhi (India)

website : [www.empirecables.net](http://www.empirecables.net)

Email : [enquiry@empirecables.net](mailto:enquiry@empirecables.net)

Toll Free No.: 1800-202-7972





# Ventura Alloy and Steels Private Limited

We are Importer, Exporter, Stockist, Distributor & Suppliers for Tool & Alloy - Special and Die Steels, Forging Components Spring Steel - Wire Rod, Square & Round Bars Coiled & Disc Springs, Tools Collets, Impact Sockets Etc.



<p><b>HOT WORK STEEL</b></p> <p>Db6 / AISI L6 / DIN2714 H13 / AISI H13 / DIN 2344 H11 / AISI H11 / DIN 2343 H21 / AISI H21 / DIN 2581 H10 / AISI H10 / DIN 2365 H12 / AISI H12 / DIN 2606</p> <p><b>ALLOY STEEL</b></p> <p>En24 / AISI 4340 / 40NiCrMo84 / 34CrNiMo6 EN19 / AISI 4140 / 42CrMo4 EN31 / AISI 52100 / 100Cr6 41Cr4 / JIS SCr440H / AFNOR 42C4</p>	<p><b>COLD WORK STEEL</b></p> <p>HCHCR D2 / AISI D2 / DIN2379 HCHCR D3 / AISI D3 / DIN2080 A2 / AISI D2 / DIN 2363 O1 / AISI O1 / DIN 2510 D5 / Cr12MoV / DIN 2601</p> <p><b>SPRING STEEL</b></p> <p>En47 / 50CrV4 / 51CrV4 / AISI 6150 / SUP10 / DIN 8159 SUP9 / AISI 5155 / DIN 1.7176 SAE 9254 / AISI 9254</p>	<p><b>PLASTIC MOULD STEEL</b></p> <p>P20+Ni / AISI P20+Ni / DIN2738 P20 / AISI P20 / DIN 2311</p> <p><b>CARBON STEEL</b></p> <p>SAE1080 MS / C45 / EN8D / ENIA / ENIA Pb C45 / AISI 1042 / JIS S45C St 52.3 / EN S355JR / JIS SM490A SAE 1018 / 25CrMo4 / JISCSM420</p> <p><b>CASE HARDENING STEEL</b></p> <p>20MnCr5 / DIN 1.7147 / SAE 5120 / JIS SMnC420H / 20MCS SAE8620 17CrNiMo6 / 18CrNiMo6 / DIN 1.6587 / BS EN353</p>
---	---	--

Unit No. 1201 & 1202, Ghanshyam Enclave, New Link Road, Near Lalipada Police Station, Kandivali (West), Mumbai - 400067. Tel.: +91 22 35034301 - 307 / 35034311 - 319 Mob.: 9819225666 & 8591313565

Head Office : Gala No. 6, Building No. 183, Indian Corporation, Mougje Gundinti(Mankoli - Phata) Dapoda, Taluka - Bhiwandi : 421302 Tel : +91 7977097655 | Email: sales@venturasteels.com | Web: www.venturasteels.com

SOVEREIGN SOLUTIONS FOR ALLOY, SPRING AND DIE STEELS

www.venturasteels.com sales@venturasteels.com +91 22 35034301 - 307 / 35034311 - 319 9819225666 & 8591313565

# Industrial Products Source

(A Product News Publication)

Vol. 21 No. 4 April 2024

**Editor & Publisher:** Mohanan N  
Mobile: 098206 70855

**Sub Editor:** Ramachandran. T  
✉: ipseditor@gmail.com

**Marketing Manager:** V Madanmohan  
Mobile: 098208 38998

**Layout Artist:** Chandrakant G. Kadam

*Single copy price: ₹30/-*

*Annual Subscription: ₹300/-*

## Regd Office

A/10 Jayshree Laxmi Puja CHS, Plot No: 78/82  
Ramachandra Nagar, Dombivli (E), Thane 421 201

## Editorial, Marketing & Advertising

104 Sudama Yash  
Nr: Ramkrishna Hotel, Kelkar Cross Road, Ram Nagar,  
Dombivli (E), Thane 421 201  
✉: ipsmaginfo@gmail.com  
ipsmag@yahoo.com

## Representatives

**Coimbatore:** Rajeev Kumar, Mobile: 094431 29073

**Industrial Products Source** is a product news monthly publication, registered with the Registrar of Newspapers for India, under No: MAHENG/2004/12919.

**Industrial Products Source** reserves the right to use the information published herein in any manner whatsoever. The Editor/Publisher to the best of their ability have tried to check the accuracy of information published in this issue which is based on the material supplied by respective manufacturers/agents/advertising agencies.

Neither **Product News Publication** nor any of its employees will be morally or legally responsible for any errors or omission. No part of this publication may be reproduced in any form without the written permission of the publisher. All rights reserved.

Printed and Published by Mohanan N on behalf of **Product News Publication** and printed at Perfect Prints, 22/23 Jyothi Industrial Estate Noori Baba Darga Road, Near Makhmali Talao Thane 400 601, and published from A/10 Jayshree Laxmi Puja CHS, Plot No: 78/82 Ramachandra Nagar, Dombivli (E), Dist: Thane 421 201.

Editor: Mohanan N

# CONVEYORS & COMPONENTS



## A WIDE RANGE TO CHOOSE

- Slats in Delrin, S.S., M.S
- Multi Directional
- Universal Flex
- Stackable
- Min / Backline Force
- Nylon, MS, SS Sprockets
- Brackets + Guides
- Clamps for Photo Cells
- Cartonator Pockets
- Tripod & Bipod
- Modular Supports

 **moldex corporation**

A-9, New Empire Industrial Estate, Kondivita Road, J.B. Nagar  
Andheri (E), Mumbai 400 059  
Phone: 022 - 4015 5959 • Mob: 99200 52389  
E-mail: info@moldex.in / krish@moldex.in  
Website: www.moldex.in

## **baltur** INDUSTRIAL BURNERS TECNOLOGIE PER IL CLIMA

Bring to you by: **NIRMAL ENERGY LTD.**, AHMEDABAD Authorised & Exclusive Rep. for INDIAN sub-continent:

### Oil / Gas / Dual Fuel Burners

- Baltur S.p.A., Italy for its Energy Efficient, High Technology, Oil/Gas/Dual Fuel Burners;
- Capacity ranging from 16.6 KW to 44650 KW
- Retrofitting of Heating Equipment, Gas Train components, Ring Main systems
- Heat Exchangers & Custom Built Equipment, Heat Transfer Equipment & Accessories
- Light Oil Burners • Gas Burners • Heavy Oil Burners
- Dual Fuel • Gas/Light Oil Burners • Gas/Heavy Oil Burners

### New Generation Burners.....TBG series

- Low NOx and Low CO emission class III defined according to standard EN 676:2000
- Excellent Quality / Price Ratio
- Many different version/execution like single stage (TBG) two stage (TBG.P) Pneumatic modulation (TBG.PN)
- Electronic modulations (TBG.ME), VFD inverter systems, Electronic and Digital Burner Management systems and more....

### Industrial Dual Block Burners: IB / TS & IBR SERIES:

- Fuel: Gas, Light Oil, Heavy Oil and Dual Fuel, Pre-heated air burners
- IB/TS Series up to 17.5 MW and IBR Series up to 44.65 MW



## **NIRMAL ENERGY LIMITED** (An ISO 9001:2015 Certified Company)

Corporate Office: 402, ISCON Elegance, Nr. Jain Temple, Prahladnagar Cross Roads, S.G. Highway, Ahmedabad 380 015, Gujarat • Tel: 079-6616 8944 • Telefax: 079-6616 8945  
E-mail: info@nirmalenergy.com / salesadmin@nirmalenergy.com / burnersales@nirmalenergy.com

### Services & Projects Support Office: NIRMAL ENERGY LIMITED / NIRMAL ENERGY ENCON SERVICES

CIU/14-16, Swetang Complex, Jodhpur Village Road, Satellite, Ahmedabad 380 015, Gujarat  
Tel: 079-2692 3170 / 2692 23151 • Fax: 079-2692 3469 • Mobile: 99789 14903 / 98258 04925  
E-mail: info@nirmalenergy.com / nirmalenergy@nirmalenergy.com / service@nirmalenergy.com

### Website: www.nirmalenergy.com

AHMEDABAD : Mr. Shankar Pillai / Mr. Arvind Modgil	Cell No. 99789 84504 / 98258 04923
BANGALORE : Mr. Arvind Modgil / Shankar Pillai	Cell No. 98258 04923 / 99789 84504
CHENNAI : Mr. Arvind Modgil / Shankar Pillai	Cell No. 98258 04923 / 99789 84504
DELHI : Mr. Arvind Modgil	Cell No. 98258 04923
INDORE : Mr. Tanu Dhoondiyal / Mr. Arvind Modgil	Cell No. 93000 77718 / 98258 04923
KOLKATA : Mr. Krishendu Ghosh / Mr. Arvind Modgil	Cell No. 94330 18350 / 98258 04923
MUMBAI : Mr. Arvind Modgil	Cell No. 98258 04923 / 099789 84503
PUNE : Mr. Abhijit Bhoskar	Cell No. 70301 10839



Dealership Enquiries are Solicited From Unrepresented Areas

## Eight Channel Temperature Data Logger with Direct USB Pen Drive Output

Countronics offers a USB Pen Drive based Data logger for up to 8 channels of Temperature (linearised for J/K/R/PT100). This state of the art logger automatically creates a data file compatible with MS Excel on the pen drive storing the Temperature values of all 8 channels along with the date and time stamp making it very simple to use. Just unplug the Pen drive and take it to your PC to view all the data. The unit allows the user to set the rate of logging from 1 second to 99 minutes. No need of any additional complicated software installations. The low cost Pen Drives offer very large storage memory space making this product very economical and easy to use for factory personnel. Individual digital offset setting for each channel allows easy calibration. Internal Real Time Clock allows data to be time stamped in real time. Available as a panel mounted version with 96 x 96 mm front facia and front loading USB Pen Drive in an ABS cabinet and aesthetically designed front panel.



Contact:

**Countronics**  
M-95, Connaught Circus, New Delhi 110 001  
☎ 011 – 2341 8487 • Mob: 98105 36887  
E-mail: [info@countronics.com](mailto:info@countronics.com)

## Submersible Borewell Pumps

MBH Pumps (Gujarat) offers Submersible Borewell Pumps from 75 mm to 305 mm (3" to 12"). Technical Specifications – Head: Up to 400 m; Discharge: Up to 400 m<sup>3</sup>/hr; HP: Up to 150; Range: v3, v4, v5, v6, v7, v8, v9, v10, v11, v12; Frequency: 50/60 Hz. Applications: Town and Village Water Supply Schemes; Cooling Water Circulation; Booster Application; Mining, Marine and Construction; Domestic; Hotels; Industries; and Agriculture. Since 1969, MBH Pumps manufactures Centrifugal pumps for submersible and surface installations. Over the years the Company has diversified its activity from the production of pumps for Agricultural applications to Domestic, Industrial, Municipal waste water, Slurry, Water intake and various other applications. All pumps are manufactured according to IS, and technical specifications of the customer to successfully satisfy many application areas.



Contact:

**MBH Pumps (Gujarat) Pvt Ltd**  
Plot No: 14, GIDC Indl Est, Naroda, Ahmedabad, Gujarat 382 330  
☎ 079 – 2282 3066, 2282 1018  
E-mail: [marketing@mbhpumps.com](mailto:marketing@mbhpumps.com)

# EMPOWERING SUSTAINABILITY THROUGH INNOVATION



Passion for Perfection  
Since 1970



## GLOBAL LEADER IN PAPER CONVERSION TECHNOLOGY

Our cutting - edge manufacturing processes guarantee high-quality machinery that enhances production efficiency to create eco-friendly and sustainable paper products

[www.sodaltech.com](http://www.sodaltech.com)



Watch Video

**K.U. SODALAMUTHU AND CO. PVT. LTD**  
428, Mettupalayam Road,  
Coimbatore – 641043, India

☎ +91 422 4242100, 2441223, 2441805  
f X @ /sodaltechco







## Synthetic Heat Transfer Fluid, Maxothermie-550™

Maxothermie-550 is a synthetic heat transfer fluid for the transfer of process heat in industries ranging from Textiles, Plywood, Chemicals, Vegetable oil extraction, Paper, Rubber, Road equipment, Paints, Pharma, Food, OEMs, Engineering, and allied industries. Maxothermie-550 has been specially formulated by process experts to withstand a wide range of operating process temperatures without losing its inherent service qualities and performance. Its features include: Operating process range: 14°F to 599°F; Withstand temperature Service Cycles; High Resistance to Oxidation; Long Service Life; Miscible/Mixable with all mineral and Synthetic Thermal Fluid Oils. Technical Properties of Maxothermie-550: Appearance: Clear Yellow fluid; Composition: Synthetic Hydrocarbon Mixture; Maximum Bulk Temperature: 305°C (extended use up to 315°C); Maximum Film Temperature: 335°C; Kinematic Viscosity at 40°C: 19 mm<sup>2</sup>/s (cSt); Density at 25°C: 867 kg/m<sup>3</sup>; Flash Point (ASTM-D92): 193°C; Fire Point (ASTM-D92): 238°C; Auto Ignition Temperature (ASTM-D2155): 366°C; Pour Point: -40°C; Boiling Point at 1013 mbar: 351°C; Coefficient of Thermal Expansion: 0.00096/C; Moisture Content: < 250 ppm. Maxothermie-550 fluid is designed for use in non-pressurized/low pressure, indirect heating systems. It delivers efficient, dependable, uniform process heat with no need for high pressures. The high boiling point of Maxothermie-550 helps reduce the volatility and fluid leakage problems associated with other fluids. While Maxothermie-550 has a relatively high flash point, it is not classified as a fire-resistant heat transfer fluid. Consequently, the use of protective devices may be required to minimize fire risk. The insurer of your property should be consulted in relation to this matter. Maxothermie-550 has been shown to be significantly less sensitive than mineral oils to the negative consequences (sludging, fouling) of thermal oxidation systems. The recommended optimum economic bulk temperature (581°C/305°C) is based on detailed thermal studies. Operation at or below this temperature provides long service life under most operating conditions. Maxothermie-550 can be utilized up to the extended maximum use temperature of 599°F (315°C). The Company also offers other products: Medium and low temperatures synthetic heat transfer products: Maxothermie-600, Maxothermie-HFF (Hot Flash Fluid) for system cleaning; and Maxothermie-FP (Food Grade).

Contact:

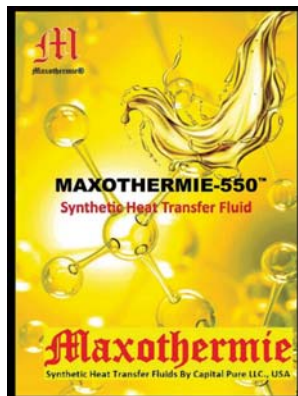
**Nirmal Energy Limited**  
402 ISCON Elegance, Nr: Jain Temple, Prahladnagar X Roads  
S G Highway, Ahmedabad, Gujarat 380 015  
☎ 079 – 6616 8944 • Mob: 98258 04923, 99789 84510  
E-mail: info@nirmalenergy.com



## Wrist Type High Voltage Alarm Model KM-HVW-289

KUSAM-MECO has introduced a new wrist Type High Voltage Alarm Detector Model KM-HVW-289. It has a wide sensing range from 1 kV to 220 kV AC. This detector provides a safe, practical and convenient new type high voltage alarm device for close-electric operator. During live electric working, the safe distance between operator and live body should not be closer than the requirement of relevant working regulations. After the operator wearing this alarm, when close to the high voltage charged body for a certain distance, according to the corresponding safe distance of voltage level, the alarm will make out the sound and light alarm to remind the electrical workers to pay attention to safety and avoid high voltage electric shock accidents.



Contact:

**Kusam Electrical Industries Ltd**  
Shop No: 18, 1st Floor, CIDCO Shopping Complex  
Plot # 9, Sector-7, Rajiv Gandhi Marg  
Sanpada, Navi Mumbai 400 705  
☎ 022 – 2775 4546, 2775 0662, 2775 0292  
E-mail: sales@kusam-meco.co.in

## Rotary Twin Gear Pump, Type RDRN

Del Pd Pumps & Gears (P) Ltd offers RDRN Type Rotary Twin Gear Pump suitable for Fuel oil, Lube oil, Veg oil, Mineral oil loading-unloading and transfer applications. This pump is well-known, widely accepted in all the industries for its efficient performance, operational reliability, compact design and noiseless operation. Many imported gear and screw pumps are replaced with Rotodel pumps in power stations, steel plants, refineries, oil installation on navy vessels and cargo ships. RDRN Series twin gear pump now offers enlarged capacity range with option of self or independently lubricated jacketed or non-jacketed construction with all sizes designed to run at synchronous speed of 4-pole prime mover to further reduce the overall cost of the pump set. Size: From ½" to 6" NB (Flanged to ASA 150 Class); Capacity from 0.5 to 200 m<sup>3</sup>/hr; Pressure up to 11 kg/cm<sup>2</sup>; Viscosity up to 1,00,000 cst; Temperature up to 110°C.



Contact:

**Del Pd Pumps & Gears (P) Ltd**  
Plot No: 113, GIDC Estate, Wadhwan City  
Surendranagar, Gujarat 363 035  
☎ 02752 – 243 047, 243 678  
E-mail: rotodel\_ad1@sancharnet.in

## Check Valves

Chromcraft Innovations Pvt Ltd offers Check Valves. The Ruby, Ceramic ball check valves are suitable at highest pressure at 750 bars available with lowest dead volume assuring pulsation-free constant flow. 1/8", 1/16" and 1/32" Ruby, Ceramic ball versions are available. Also universal Check valve cartridges are available for any type of check valve. The Company also offers Vial Crimpers, Vidal De-Crimpers, Peek Fingertight Fittings, Suction Filters, ZDV Union, PEEK/SS316, Rheodyne Needles, Rotor Seal, Thrust Bearings, Gas Chromatography Spares, Column End Fittings/Block Nuts, Graphite Ferrules, Plunger Seals/Piston Seals, Plungers/Pistons, Solvent Safety Caps, PTFE/Butyl Septa, PTFE/Silicone Septa, etc.



Contact:

**Chromcraft Innovations Pvt Ltd**  
Plot No: E-52, Gala No: C-237, Tiny Industrial Area  
MIDC, Aurangabad, Chhatrapati Sambhajanagar  
Maharashtra 431 001  
Mob: 90115 53881, 92094 22798  
E-mail: chromcraftinnovations@gmail.com

## Water Bath

Ganesh Scientific Industries, manufacturers of equipments and Instruments for R&D, Quality Control Laboratories offers Water Bath. Salient Features: Fully made of stainless steel with powder coated paint finish and Mat finish for GMP Models; Advance Digital PID Type Temperature Controller; Temperature Range: Ambient +5°C to 99°C; Working Range: Ambient +5°C to 99°C; Heater: Electrically heated water immersion heaters as per IS Standard; Heat up time: Up to 99°C within 45 minutes; Accuracy: ±1°C; Resolution: 1°C/0.1°C; Insulate with high heat resistive cerawool Insulation Operating voltage 230 Volts AC, 50 Hz; For safety settable over shoot Alarm and safety fuse.



Contact:

**Ganesh Scientific Industries**  
8 Shikhar CHS, Near Star Colony, Manpada Road  
Dombivli (East), Dist: Thane, Maharashtra 421 204  
Mob: 93247 94768 / 98209 45284  
E-mail: gsidbl@hotmail.com



**Toshniwal®**

# VACUUM PUMPS

OIL LUBRICATED TECHNOLOGY

- Multivane Oil Lubricated Pump. Compact Direct Drive
- Design Ensure Long Life, Silent with Low operating temperature
- High Water Vapour Handling Capacity
- We offer process integrated VACUUM Solutions for Evaporators Drying/Distillation

**TOSHNIWAL INSTRUMENTS (MADRAS) PVT. LTD**  
267, Kilpauk Garden Road, Chennai - 600 010, India / Tel: +91 44 26448983 / 8558 / 5626  
Email: sales@toshniwal.net / Web: www.toshniwal.net  
Branches : Bangalore, Delhi, Hyderabad, Kolkata, Mumbai, Vadodara

## Reversible Hammer Crusher

MASYC, an ISO 9001-2008 certified company specializes in the field of Bulk Material Handling System, Conveyor Equipment, Crushers and Screens etc. The Reversible Hammer Crusher is manufactured based on proven technology and under in-house strict quality control. It has the unique design feature such as Welded Casing, Screwed Liner with High Carbon Steel Plates, Hammer heads made of chrome alloy cast steel or manganese steel depending upon the application. Rotor shaft is made out of forged steel, Hammer grinding path with Wear Resistant Plates, which are Mechanically/Hydraulically adjustable and Dust Proof Spherical Roller Bearing. It crushes material in two stages ie, initially the material is reduced by impact between hammer and material followed by scrubbing action (attrition) against breaker plate. Masyc Reversible Hammer Mill is used for Hard Coal, Lignite, Cooking Coal, Lime Stone, Gypsum and other soft and medium hard material. These Mills are rugged in structural, design and easy to maintain, having high throughput and low wear. The maximum reduction ratio can be as high as 12:1 depending upon the WBI of the material. Masyc can offer Reversible Hammer Crusher up to a capacity of around 700 TPH and having Rotor dia 2000 mm.



Contact:

**Masyc Projects Pvt Ltd**  
23 Community Centre, Mayapuri  
Phase-1, New Delhi 110 064  
☎ 011 – 2811 5453 • E-mail: [masyc@masycproject.com](mailto:masyc@masycproject.com)

## Pipes & Fittings

Chemical Process Equipments Pvt Ltd (CPP) is a pioneer and a market leader for 50 years in the field of design, manufacture and installation of GRP/FRP/RTRP Equipment and GRE Piping. The Company manufactures pipes by the following methods: Helical Filament Winding; Band Binding; Continuous Filament Winding. Size Range: 15 mm dia to 4000 mm dia. The fittings are generally manufactured by Hand layup/Filament winding method to achieve circumferential and axial strengths. Chopped strand Mat, Woven Roving and Roving are impregnated with resin and are placed on moulds till the designed thickness is achieved. Size range: 15 mm dia to 4000 mm dia. Items: 90° Elbow, 45° Elbow; Full Face Flange; Equal Tee, Unequal Tee; Concentric Reducer, Eccentric Reducer; Stub end; Special Fittings, etc. Industries Served: Chemical; Gas Cleaning Plant; Non-Ferrous Metallurgy; Oil and Gas/Offshore; Fertilizer; Pharmaceutical, etc.

Contact:

**Chemical Process Equipments Pvt Ltd**  
BSD Marg, Govandi, Mumbai 400 088  
☎ 022 – 6723 0600 • E-mail: [info@cppiping.com](mailto:info@cppiping.com)

## Submersible Sewage Pumps

MBH Pumps (Gujarat) Pvt Ltd offers Submersible Sewage Pumps, which operate directly in the liquid being pumped that means they require neither special housing nor a superstructure to support them, considerably reducing construction costs. They are smaller than non-submersible counterparts as the motor and hydraulics are integrated into one compact unit, resulting in smaller pumping stations that are less complex to build. Operating submerged they take-up less space, noise and cooling problems are virtually eliminated. The Company has a wide variety of submersible sewage pumps for various applications. The NS Series and PST Series pumps are perfect solution for domestic and municipal use where as their Contractor pumps and Ni-hard series slurry pumps can handle the most abrasive slurries from infrastructure to power industries. Features: Robust – all components are made from robust materials for easy maintenance and long life; Powerful – the motor is specially designed for reliable operation in submersible applications and it can run continuously without overheating. Durable – Heavy-duty bearings with long life provide peace of mind. Environmentally friendly – the cooling system is designed to use its surroundings to cool the pump, no use of environmentally hazardous fluids such as oils. Safe and straightforward – Cable entry prevents both cable strain and leakage. Consistent – the double mechanical seal provides extra reliability and protects against leakage. Flexibility – Drilled pump housing, ready for any installation method. Applications: Municipal sewage pumping stations and sewage treatment plants; Wastewater pumping, and Storm-water pumping stations; Industrial effluents pumping, and effluent treatment plants; Slurry handling for power and steel industry; etc.



Contact:

**MBH Pumps (Gujarat) Pvt Ltd**  
Plot No: 14, GIDC Indl Estate, Naroda  
Ahmedabad, Gujarat 382 330  
☎ 079 – 2282 3066, 2282 1018  
E-mail: [marketing@mbhpumps.com](mailto:marketing@mbhpumps.com)

## Flanges

Mahesh Industries manufactures all types of flanges. Their range includes: Plate Flanges – Slip-On, Blind, Lap Joint, Screwed and Threaded Forged Flanges – Slip-on, Blind, Lap Joint, Weld neck, Screwed, Ring Joint Type, Socket Weld, Spectacle, and Orifice Flanges.

Contact:

**Mahesh Industries**  
R-547 TTC Indl Area, MIDC Rabale, Navi Mumbai 400 701  
☎ 022 – 2087 0394 / 2087 2930  
E-mail: [info@maheshindustries.net.in](mailto:info@maheshindustries.net.in)



# International Machine Tools & Industrial Trade Fair



# INTEC 2024

Organised by



**CODISSIA**  
Intec Technology Centre

**06<sup>th</sup> to 10<sup>th</sup> June 2024**

**CODISSIA Trade Fair Complex, Coimbatore**

## CONCURRENT EVENTS



**Advanced  
Manufacturing  
with Low Cost  
Machinery**

### Exhibitors' Profile

- Industrial Electrical & Electronics
- General Engineering
- Machinery for Process Industry
- Metallurgical Plant & Equipments
- Textile Machinery & Equipments
- Fabrication Machinery & Equipments
- IT Consulting & Service Providers
- Machine Tools & Accessories
- Hydraulics & Pneumatics
- Material Handling Equipments & Machinery
- Foundry Equipments
- Pumps & Fittings
- Precision Tools, Cutting Tools, Dies & Moulds, Welding
- Instrumentations Automation
- Factory Cleaning & Pollution Control Equipments
- Industrial Consumables
- Industrial Robotics & Automation
- Sheet Metal Press & Laser Cutting
- Power Tools & Testing and Measuring Equipments
- 3D Printing and Laser Marking

Platinum Category  
Exhibitor



Always Better.

Official Banker



YOUR PERFECT BANKING PARTNER

Diamond Category  
Exhibitor



Conference Partner



www.texasventures.us

Gold Category  
Exhibitor



E-magazine Partner



www.industry40.com

**Halls  
A, B, C, D & E  
Fully Booked**

**Few Stalls  
Available in Hall - G  
Rush Your  
Bookings**

✓  
6 Halls

450+  
Exhibitors

70,000+  
Visitors

2000+  
Products Display

Ph : 99655 15182 / 88705 60333 / 85080 22000 / 75029 22000

E : [intec@codissia.com](mailto:intec@codissia.com) W : [www.intec.codissia.com](http://www.intec.codissia.com)

## Special Automatic Shot Blasting Machine for Internal and External Cleaning of Submersible Pump Casing

MEC SHOT, a renowned name in Design, Development and Manufacturing Surface Preparation, Finishing, Shot Peening Machines, Media Conveying, Blast Room, Paint



Pneumatic Grit Valve



PLC Operated Electric Control Panel



Pneumatic Panel

MEC SHOT has recently designed, manufactured and ex-

ported Semi-Automatic Special Air-operated Shot Blasting Machine to one of the world renowned companies in the field of electrical products for accomplishing above task. The shot blasting machine works on direct feed principle incorporated with X-Y manipulator of nozzles for internal and external both cleaning and revolving job on the PU rollers. The nozzle reciprocation through hydraulic arrangement ensures precise movement. The multi blast nozzles fixed on hydraulic reciprocation stand de-scale and deburrs the submersible pump casing at one satellite position while the residual dust particles are air washed at another position respectively.



X-Y Manipulator

The machine provides for recovery and reclamation of used abrasive from blasting cabinet and cyclonic separation of dust and reusable abrasive. The very fine dust is trapped in pleated dust bags and clean air is discharged in atmosphere to keeping the environment clean and eco-friendly.

Machine Features: PLC Controlled Machine; Safety interlocks; Media Sensor and Level Sensor; X-Y Manipulator; Triplet Nozzle; Angular Nozzle for internal blasting; Acoustic Chamber; Pneumatic Operated Automated Door; Photo Sensor on Door for operator safety; PU Roller for Job rotation; Pleated Bag Dust Collector; Media – Glass Bead/Alu. Oxide.

Contact:

**Mec Shot Blasting Equipments Pvt Ltd**  
**B-14, Parshvath Ind Estate Yojna, Khasra No: 160**  
**Mogra Kalan, Tehsil Luni, Jodhpur Rajasthan 342 802**  
**☎ 0291 - 274 0609, 274 4068**  
**Mob: 70147 31363**  
**E-mail: mail@mecshot.com**

## Research Chemicals

SimSon Research Chemicals division offers customer focused solutions to basic and advanced chemical applications. The range of chemicals is: Acetophenones, Acids and Phenols, Alcohols, Aldehydes, Arl/Alkyl, Alkynes, Amides, Amines, Amino Acids, Azoles, Azetidines, Benzacetoneitriles, Benzophenones, Bulk Fine Chemicals, Baronic Acids, etc. Your one stops solution for API and Fine Chemicals Sourcing for Pharmaceutical market. A Company focused on being a qualified worldwide partner with high competence in finding Fine Chemical Intermediates and API (Active Pharmaceutical Ingredients) for Chemical and Pharmaceutical markets.

Contact:

**SimSon Chemie**  
**B-307/407, Sarita Building, Prabhat Indl Estate**  
**Dahisar (East), Mumbai 400 068**  
**☎ 022 - 4006 8689 • Mob: 82910 96869**  
**E-mail: sales@simsonpharma.com**

## Voltage Tester Model KM 66/KM 69

KUSAM-MECO offers 2 voltage testers in their vast range of Digital Test and Measuring Instruments. The Testers have highest safety 'UL/ETL' approval. Features are: Model KM 69 is with display and Model KM 66 is without display. KM-69 displays DC voltage from 0.1 V-1000 V, AC voltage from 0.1 V-1000 V in 8 steps. The sensing is TRMS. It also has AC Detection Shaker and RCD leakage-path. RST (RYB) Phase Sequence rotation and Detection it has Non-contact and Probe contact EF Detection–Auto DCV, ACV and Audible continuity selection. Can check RCD leakage load for 230 V AC / 30 mA RCD Circuit Breakers. Backlight display and flash light for easy viewing in dark. It is rated for IP 65 protection. Low Battery Warning and Auto Power off function. The housing is made from rugged fire retardant casing. Model KM-66 has similar functions but without display.



Contact:

**Kusam Electrical Industries Ltd**  
 Shop No: 18, 1st Floor, CIDCO Shopping Complex, Plot # 9  
 Sector-7, Rajiv Gandhi Marg, Sanpada, Navi Mumbai 400 705  
 ☎ 022 – 2775 4546, 2775 0662, 2775 0292  
 E-mail: sales@kusam-meco.co.in

## Servo Controlled Hydraulic Press Brake 2-Axis Model HPB-S

GMT Engineers Pvt Ltd offers 2-Axis Servo Controlled Hydraulic Press Brake Model HPB-S. Its Features: HPB-S is an accurate Press Brake with Servo Controlled X and Y Axis; Optional Hand operated or Motorised Crowning can enhance the bending accuracy; The Tetraelec controller gives the performance of any international controller of its class; Convenient Front Arm Support System and back gauge fitted with Four Fingers placed on Linear Guides with up and down facility provided to enhance operator performance; Imported German Hydraulics for Trouble free running; Electrical Panel with Standard elements such as Schneider or Telemecanique. The Company's products range includes: Electro Hydraulic CNC Press Brake, CNC Press Brakes, CNC Fiber Laser Cutting Machines, etc.



Contact:

**GMT Engineers Pvt Ltd**  
 H-7A, Krupa Colony, 1st Avenue  
 Ashok Nagar, Chennai 600 083  
 ☎ 044 – 2371 1881, 2489 6028 • Mob: 98409 11881  
 E-mail: Prasad@gmtoffice.com

# a unique innovation, with trust and quality...

Commercial Gauges	Industrial Gauges	Low Pressure Capsule Gauges	Economical Gauges	Chemical Sealed Gauges	Compact Sealed Gauges	Gauge Saver
Triclover Sealed Gauges	Homogenizer Gauges	Mud Gauges	Bi-Metallic Temperature Gauges	Comparison Tester	Comparison Tester	Needle Valves

## Manufacturers of Pressure Gauges, Temperature Gauges, Testing Equipments & Accessories

### ARBUDA INSTRUMENTS

Office : E-11/1, G.I.D.C., Sector-26, Gandhinagar - 382 026 (Gujarat)  
 Telefax: 079 - 2328 7990 • Mob: 090337 11390 / 093282 97128  
 E-mail: arbudainst@yahoo.com • Website: www.arbudainstruments.com  
 Mumbai Office : 23/25, Maruti Mandir Marg, Mumbai - 400 004  
 Tel.: 022 - 2382 4101, 6636 2754

Syphons

## Hydraulic Products

Deepak Ind Hydraulics manufactures a wide range of hydraulic products such as Hydraulic Cylinders, Hydraulic Power Packs, Gear Pumps, Vane Pumps, and Plunger

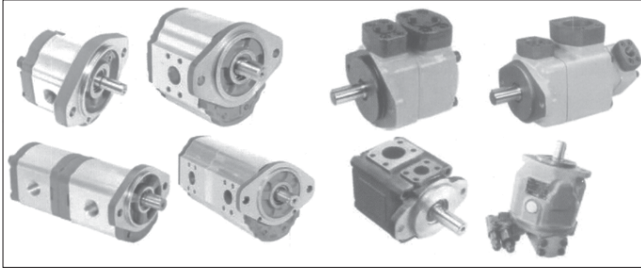

Pumps, Hand Pumps, Mobile Valves, Solenoid Valves, Hydro Motor, Steering Units, Prefill Valve, PCM & Pressure



Relief Valve, Counter Balance Valve, Hydraulic Hoses and Connectors, Bell Housing, Pressure Gage, Manifolds, Accessories, Honed Tubes and Plotted Rods, Seals, Coolers, Seamless Tube and MSC, etc.

Contact:

**Deepak Ind Hydraulics**  
1<sup>st</sup> Kasthuribai Street, Ganapathy  
Coimbatore, Tamil Nadu 641 006  
Mob: 75400 75756 / 75400 75775  
E-mail: marketing@deepakind.com

## LUBERR LUX Pumps

SVA Rikkon Lubes Private Limited offers LUBERR LUX Pumps. With LUBERR LUX automatic lubrication system you can be rest assured that under all operating conditions the right amount of grease will be delivered to the required bearing at the right time intervals, so that the machine or vehicle always have the maximum utilization without any downtime, breakdowns. Also provides maximum protection against the abrasion and pollutants. Technical Specification – Model: LUBX; Operating Voltage: 12/24 V DC 230 V AC; Noise: < 70 dB (A); Operating Temperature: -25°C to +80°C; Humidity: 90%; Reservoir Capacity: 2, 4, 8, 10, 12, 18, 22, 36 liters; Max number of Output: 3; Max working pressure: 300 bar.



Contact:

**SVA Rikkon Lubes Private Limited**  
No: 203, Nagesawara Rao Road, 2nd Extension  
Athipet, Ambattur, Chennai 600 058  
☎ 044 – 2688 0080 • Mob: 98400 40083  
E-mail: sales@rikkonlube.com

## T+RH and Differential Pressure Transmitters

Libratherm offers T+RH and Differential Pressure Transmitters. Key Features: Incorporates accurate T+RH sensors and Pressure sensors; Absolute, Differential, Vacuum Pressure measurement; Accurate T+RH measurement and re-transmission; 0 to 60°C/0 to 80°C/0 to 100% RH; 0 to 10 bar, ± 9999 Pascal, ±700 mm WC; Stable 4-20 mA/0-10 V outputs; Calibration through internal presents; SS/Metal stem for T+RH Sensing; Operates on 24 V DC isolated from Outputs; Duct mount/Wall mount/Field mount enclosures. Applications: Medical and Pharmaceutical test equipment; Process control and Factory Automation; Hydraulic/Pneumatic Systems; Air Humidifier/Dehumidifier/HVAC Equipment; Leak Detection and Blockage Detection in Air Filters.

Contact:

**Libratherm Instruments Pvt Ltd**  
401-403 Diamond Indl Estate, K P Road, Dahisar (East),  
Mumbai 400 068  
☎ 022 – 4255 5333 • Mob: 98700 11544  
E-mail: libratherm@libratherm.com



## Spray Dryer

Spray Drying is a unit process, which converts solution, suspension or paste into dried particulate form by spraying the fluid in hot drying medium. Spray drying may proceed concurrently, counter currently, or as a mixed flow process. Spray Drying can be achieved in stages depending upon the product quality. The feed is atomized using a rotating wheel or a nozzle, and the spray of droplets immediately comes into contact with a flow of hot drying medium, usually air selection of the atomizer is solely dependent on the required final product quality and particle size. SVAAR offers single, two and three stage Dryers. Three stage dryers are often used when the final product agglomeration is required. Spray drying is used to dry pharmaceutical fine chemicals, foods, dairy products, blood plasma, numerous organic and inorganic chemicals, rubber latex, ceramic powders, detergents, and other products.



Contact:

**SVAAR Process Solutions Pvt Ltd**  
Office No: S-2, Star Zone Building E, A-Wing, 4<sup>th</sup> Floor  
Nashik-Pune Highway, Nashik Road  
Nashik, Maharashtra 422 101  
☎ 0253 – 246 9032 • Mob: 92842 82341  
E-mail: info@svaarprocess.com

## Digital Pressure Gauges + Transmitter

Arbuda Instruments offers Digital Pressure Gauges + Transmitter. Features: Nominal size: 63 and 100 mm; Accuracy: +0.25% and 0.15% of full scale; Case and Bezel: ABS plastic and aluminium anodized; Wetted parts: SS 304L/DD 316L; Scale range: -1 to 700 kg/cm<sup>2</sup>; Battery life: 2 years power saving mode/1000 hrs cont. Applications: Generally used for corrosive gases and liquid media and for calibration lab use.



Contact:

**Arbuda Instruments**

**E-11/1 GIDC Sector-26, Gandhinagar, Gujarat 382 026**

**Telefax: 079 – 2328 7990 • Mob: 90337 11390 / 93282 97128**

**E-mail: info@arbudainstruments.com**

## KirloSmart IoT Remote Monitoring Solutions

Kirloskar offers KirloSmart IoT Remote Monitoring Solutions. It is an IoT (Internet of things) product with unique capability of measuring and transmitting the field of parameters for Remote Monitoring on KBLs web based portal/Cloud for analytics and generating alerts for the probable causes leading to failure of the pump/motor. KirloSmart enabled system helps user in monitoring the pump health and operation behaviour of pump on real time basis by approximately sensing the critical health and operational parameters of the pump. KirloSmart remotely manages the pump/motor and notifies its current state by transferring the data using wired Ethernet or Mobile Data (GPRS). Unique Features: Predictive maintenance alerts with probable causes (SMS and Email); 24x7 Real Time Monitoring, Historical Data and Trend monitoring, Graphical Indications; Remote Diagnostic of the issues at early stages; Pump Spares management – Estimation of service life; Storage of data in event of communication failure; User configurable Sensors; Communication mode selection (Mobile Data (GPRS/Ethernet); Cost effective, Simple, Plug and Play; Facilitates easy Integration with existing equipments. Benefits: Reduces operational cost, repair cost, labour hence improves profitability; Reduces unplanned breakdown, improves process/plant Safety and reliability; Increased equipment life and less down time; Eliminates cost of assets like Servers, Modems, Computers, etc.

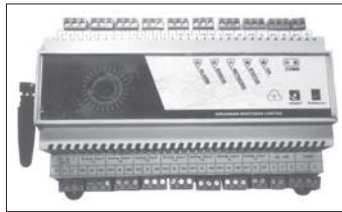

Contact:

**Kirloskar Brothers Limited**

**Yamuna, Survey No: 98 (3-7), Plot No: 3, Baner**

**Pune, Maharashtra 411 045**

**☎ 020 – 2721 4444 • E-mail: marketing@kbl.co.in**

## Power Cables

Empire Cable supplies power cables with PVC insulation for power transmission. Voltage grade 650/1100 volts (U<sub>0</sub>/U) provided with ISI marking IS 1554 (Pt-1), with or without HR/FRLs properties. Screening can be provided if desired. The cables conform to standard specifications like IS 1554 (Pt-1), IEC 502, BS 6436/87. Configuration: Single core up to 1000 sq mm, multi-core up to 400 sq mm x 3-1/2 cores; Construction: Conductor is aluminium/copper, solid/stranded circular/compacted/sector shaped. Insulation is PVC; Mechanical protection: Galvanized steel wire/strips/double helical steel tape; aluminium wire amounting for single core cable; Inner and outer sheath – PVC black/grey or as per requirement.



Contact:

**Empire Cable Industries (P) Ltd**

**Plot No: 115, Phase-II**

**Badli Industrial Area, Delhi 110 042**

**☎ 011 – 2387 4632 • Fax: 011 – 2386 1610**

**E-mail: empirecables@yahoo.co.in**

### FITZER

World Class Product Brand

PROCESS, MEASURING INSTRUMENTS & AUTOMATION

**PRESSURE**

- LIQUID COLOUM MANOMETERS
- DIGITAL MANOMETER
- DIGITAL PRESSURE GAUGES
- BAROMETER
- VACCUM MANOMETER
- PRESSURE SWITCHES

**FLOW**

- GLASS TUBE / ACRYLIC ROTAMETERS
- METAL TUBE ROTAMETER WITH TRANSMITTER / FLOW INDICATOR TOTALIZER
- BY-PASS ROTAMETER
- ELECTROMAGNETIC FLOWMETER
- FLOW SWITCHES
- AIR VELOCITY KIT

**LEVEL**

- LIQUID LEVEL INDICATORS
- LIQUID LEVEL TRANSMITTER
- LIQUID LEVEL SWITCHES (FLOAT OPERATED)
- CONDUCTIVITY LEVEL SWITCHES
- CAPACITANCE TYPE LEVEL TRANSMITTERS

**FITZER** <sup>®</sup> Regd. Correspondence Address:  
 INSTRUMENTS COMPANY (INDIA) Atali, Near Ambivali Stn. (W), P.O. Mohone, Tal. Kalyan, Dist. Thane-421 102  
 Mobile: 8691816354 / 8691816355 / 8691816356 / 9426470248  
 E-mail: fitzerindia@hotmail.com / fitzergujarat@rediffmail.com

Dealership Enquiries Solicited Website: www.fitzerindia.com

## Coolant Pumps VDS/VDC Series

CRI Pumps offers Coolant Pumps VDS/VDC Series. These Coolant pumps are vertical single/multistage immersible type designed for pumping coolants in machine tools applications. The pumps are designed to mount on the top of the tanks with the chamber assembly immersed in the liquid to be pumped. The pumps come in various sizes and stages to provide the flow, the pressure and the immersion depth required. Coolant Pumps are highly versatile and suitable for use in a wide range of machine tool applications. Salient Features: Energy saving; Low heat input into the cooling lubricant; Increased cooling efficiency; Better performances of the machine centre; Simple integration with the machine centre; Bottom and Side Suction ensures optimum liquid passage. Specifications/Operation Limits: VDC – Max Power: 18.5 kW; Max Flow: 20 m<sup>3</sup>/hr; Max Head: 240 m; Max Liquid Temp: 90°C. Applications: EDM Wire Cutting and Printing machines; Boring, Mining, Grinding and Turning Centres; Industrial washing and Cleaning; Cooling System and Cutting Oils; Spark Machine Tools; Filtering Systems.



Contact:  
**CRI Pumps Private Limited**  
7/46-1, Keeranatham Road, Saravanampatty  
Coimbatore, Tamil Nadu 641 035  
☎ 0422 – 711 7000, 711 70001 • E-mail: bcsmtk@cripumps.com

## Process Pumps EO/EOS Series

Egger Pumps offers Process Pumps EO/EOS. Its Features: Pumping of fluids with gas contents up to 25%; Semi-open impeller; Different numbers of blades. Facts and figures –

Nominal dimensions: DN 50-500 mm; Flow rate: up to 1500 l/s; Differential Head: Up to 150 m; Pressure: Up to 30 bars; Temperature: Up to 180°C. Applications: Demanding fluids in the chemical and petrochemical industries; Multiphase mixtures for reactor loops; Aerated fibre suspensions in the pulp and paper industry; Wastewater and viscous materials in wastewater technology; Sledges; Numerous abrasive and corrosive fluids.



Contact:

**Egger Pumps India Pvt Ltd**  
SF No: 206, Kannampalayam (PO), Suler (Via)  
Coimbatore, Tamil Nadu 641 402  
☎ 0422 – 268 9855 • E-mail: info.india@eggerpumps.com

## Modular NC Plasma Cutting Machine, Table Type

System Engineers Cutting & Welding Pvt Ltd offers Table Type Modular NC Plasma Cutting Machine. This type cutting machine is one high speed CNC Plasma cutting machine. It can be compatible with all the power sources as per the production requirement of customer. It is convenient to install and commission.



Special Features: Longitudinal and transverse drive on heavy duty LM guide ways; Machine structure new design, no need to do the foundation work or fabricate any cutting table; Specially designed cutting table with centralized fume suction duct to allow suction from gantry area and saving energy consumption for fume removal; Special arrangement for dross recovery and small components, which may fall during cutting. Specifications – Cutting Width Range: 1500 mm; Cutting Length Range: 3000 – 6000 mm; Drive System: Double drive; Drive Speed: 50-30000 mm/min; Servo Motors: Panasonic AC Digital Servo motors; Axis: LM Guide on both sides for longitudinal and Cross Axis; CNC Controllers: Hypertherm/Beckhoff; Height Sensor: Hypertherm/Kjellberg/HT; Plasma cutting speed: According to the Plasma power source; Optional attachment: Laser head, Drilling, Punch marking. Fume Extraction/Under water cutting is also provided on customer's requirement.

Contact:

**System Engineers Cutting & Welding Pvt Ltd**  
Plot No: 24, Pragati Vihar, Sector 59  
Faridabad, Haryana 121 004  
☎ 0129 – 230 7004, 401 4466  
E-mail: sales@systemengineers.co.in

## Sight Flow Indicator

R K Dutt offers a wide range of Sight Flow Indicators. Features are: with larger view area, drip lip - standard for all metallic body; Indicator: flapper or rotary for invisible liquids or gases;

Sizes: wide range from 15 NB to 250 NB; Choice of glass: Indian – Sodium Silicate for 50°C to 120°C; Imported – Borosilicate DIN 7080 std for -50°C to 300°C; Choice of material: SS, CS, A105, A182 F, semi-welded, seamless, PP, PTFE. RK Dutt manufacturing liquid level indicating, measuring and controlling instruments since 1974.

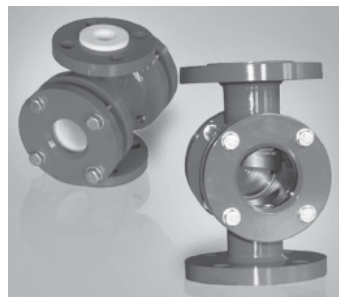

Contact:

**R K Dutt Concerns**  
Plot A, 88, Road No: 18, Neheru Nagar, Wagle Industrial Est  
Thane West, Maharashtra 400 604  
☎ 022 – 6724 8787 • E-mail: pisales@rkdutt.com

## Acrylic Body Manometers

Fitzer Instruments offers solid acrylic body U-tube, inclined and single limb type manometers, which are accurate and dependable as well as highly versatile for many applications. Scales are graduated to correct for the drop in the well level for inclined and single limb manometer for high accuracy. General specifications – Body: fabricated in 25/32 mm thick acrylic plastic solid block virtually unbreakable stable and free from distortion; Scale graduation: plastic milky white printed scale; Manometric fluid: red gauge oil, specific gravity 0.823; End connection: 1/4" BSP (F) or PVC nozzle type; Packing: Neoprene/PTFE; Mounting: wall panel and flush mounting holes; Accessories: Plastic box contains liquid storage bottle and liquid filling funnel arrangement – zero adjusting knob, level bulb; Accuracy:  $\pm 0.25\%$ ,  $\pm 0.1\%$  of FSD or better; Test pressure: 1.5 time of operating pressure; and Temperature: below 70°C.

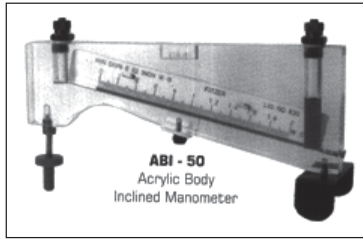

Contact:

**Fitzer Instruments Company (India)**  
Atali, Near Ambivali Station (W), PO: Mohone  
Tal: Kalyan, Dist: Thane, Maharashtra 421 102  
Mob: 86918 16354 / 86918 16355 / 86918 16356  
E-mail: fitzergujarat@rediffmail.com

## Pipe Conveyors

MASYC Projects Pvt Ltd offers Pipe Conveyors. It has all the advantage over a typical conventional Belt Conveyor while adding further characteristics of having Horizontal



and Vertical curves. It can also have steep angles without any transfer points. It can convey dust as well as bigger lump sizes; and is particularly recommended in Cement Industries, Power, Fertilizer, Steel and Glass Plants etc.

Contact:

**MASYC Projects Pvt Ltd**  
23 Community Center, Mayapuri Phase-I  
New Delhi 110 064  
☎ 011 – 2811 5745, 2811 5453  
Fax: 011 – 2811 6850  
E-mail: masyc@masycproject.com

## Rotary Triple Twin Gear Pump Type NDX Series

Del Pd Pumps & Gears Private Limited supplies Rotary Triple Twin Gear Pump Type NDX. NDX Series pumps are designed to handle bulk volume of viscous and semi viscous liquids quite efficiently at medium pressure up to 11 bar. This pump can be coupled directly with drive as impeller speed reduction is made possible within pump, making it very compact and cost economical and thereby reducing the overall cost, and space. The timing gear reduces the noise level and enhances the working life of the pump. This pump out performance twin Screw pump in all aspect in this range and they are suitable for wagon decanting, cargo-unloading of various viscous liquids such as edible oils, Fuel oils, viscous chemicals, etc. Step-down Versions are also available. Type MDX comes without reduction gears whereas Type JDX comes without timing and reduction gears and Type JDB is with bush bearing suitable for molasses applications. Size: from 5" to 12" NB (Flanged to ASA 150 Class); Capacity from: 80 m<sup>3</sup>/hr to 550 m<sup>3</sup>/hr; Pressure: up to 11 kg/cm<sup>2</sup>, Viscosity is up to 1,00,000 CST, and Temperature up to 110°C.



Contact:

**Del Pd Pumps & Gears Private Limited**  
Plot No: 113, GIDC Estate, Wadhwan City  
Surendranagar, Gujarat 363 035  
☎ 02752 – 243 047/243 464/243 678  
Mob: 99988 17576  
E-mail: info@delpump.com

## Hydraulic Clamping Systems

Andreas Maier Workholding Technology Pvt Ltd offers Hydraulic Clamping Systems like: Pressure Generators/ Hydraulic Power Packs; Hollow Rod and built-in Cylinders; Threaded and Block Cylinders; Push-Pull Cylinders, Swing Clamps; Vertical link Clamps and Toggle Clamps; Pull-down Clamping Elements, Centring Clamp; Support Elements, Compensating Clamps; Low-pressure Clamping Elements; Valves, Pressure Switches, Rotary Couplings and accessories; Tool clamping for presses, etc. The Company's products range includes: Marking and Cleaning Tools, Wireless Sensing Systems, Magnetic Clamping Systems, Standard Clamping Elements, Single and multiple Clamping Systems, Block-Clamping Systems, Hand Tools, etc.



Contact:

**Andreas Maier Workholding Technology Pvt Ltd**  
No: 116, 2<sup>nd</sup> Cross, NHCS Layout, Basaveshwaranagar  
Bengaluru, Karnataka 560 079  
☎ 080 – 2323 8444 • E-mail: amfindia@amf.de

## Submersible Sewage Pump

Jagdish Textile & Engg offers Submersible Sewage Pump. The features are: this range adopts a high-efficient 4P motor that has been tested by serious quality control and applied high-class insulation to provide long-term operation; a motor installed with an over-load protector to prevent the motor from overheating and overloading; the installation of a high-quality SIC seal to produce high wear resistance and leak-proof motors; speed of flow is superiorly designed and can be applied within large pump housings and impellers to achieve high efficiency and high performance for any wastewater; inner cable wires and cable base are upgraded by filling EPOXY to raise humidity resistance; drainage of the food market; wastewater treatment of animal husbandry, water refining tank waste water plant; drainage of the building basement, waste water treatment of the food industry; pulp and paper industry; steel mill; and other industries, etc. The company is a manufacturer, importer, and exporter of supreme grade high pressure pumps, car washer pumps, etc.



Contact:

**Jagdish Textile & Engg Co**  
**Ramoliya Bulding, Opp: Ashok Niwas, Kadia Kui**  
**Relief Road, Ahmedabad, Gujarat 380 001**  
**Mob: 98983 20500 • E-mail: info@jtecump.com**

## Precision Tubes

Hansa Tubes offers Precision Tubes. Their features are: They have 1 no's of high-speed tube mills with sizes ranging from ½' to 3' and an installed capacity of 24,000 MTPA; these are catering to the automobile and furniture industries. In the bicycle industry, they are supplying the world's No. 1 bicycle manufacturers, Hero Cycle and Avon Cycle; and these have an ultramodern plant at Derabassi. The requirement for raw material for C.R. precious tubes is being met by its narrow cold-rolled steel mill. The company was established in 1994. A simultaneous plant was set up in the industrial belt near Chandigarh at Dera Bassi in the state of Punjab with an in-house facility for cold-rolled steel strips and coils and high-frequency ERW precision tubes. Now it is an ISO: 9001 certified company and has 2 CR mills and 1 tube mill with a fully equipped workshop and testing lab to cater to the basic requirements of customers for end applications.

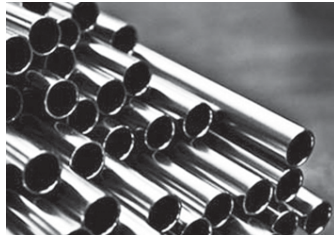

Contact:

**Hansa Tubes Pvt Ltd**  
**181/25, Indl Area-1, Chandigarh, Punjab 160 002**  
**Mob: 95925 00077 • E-mail: arjit.hansa@gmail.com**

## Electric Actuated Butterfly Valve

Trisha Engineers offers Electric Actuated Butterfly Valve. The features are: this plastic actuator body passes impaction and acid-base tests and also meets SGS. Valve position can be adjusted from 15 degrees to 90 degrees. The assembly of actuators and valves meets the EN ISO 5211 standard. Improved PP disc to enhance the performance. Thickened body and seal to extend the service life. Materials meet drinking water standards; the material has been modified by nanometers to improve the pressure resistance and impact resistance. Raw materials add anti ultraviolet absorbent and antioxidants, improving durability and aging resistance. The company is a leading supplier of quality sinking thermoplastic products, including PVC / PP / CPVC valves, pipes, and fittings. They cater to various industries like water treatment, metal finishing, chemicals, swimming pools, and spas.

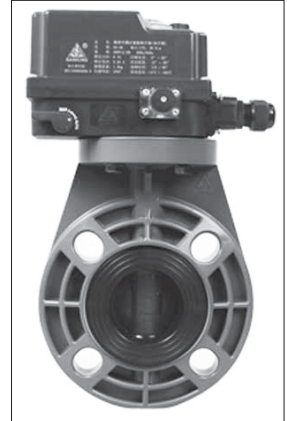

Contact:

**Trisha Engineers**  
**#11, Sri Nivasam, Bull Temple A Cross, Behind Uma Theatre**  
**6th Main, Chamarajpet, Bengaluru, Karnataka 560 018**  
**☎ 080 – 2661 4315 • Mob: 93412 70830**  
**E-mail: trishaengineers@yahoo.com**

## Compact or Package Substation

Excel Power Switchgear Pvt Ltd offers Compact or Package Substation. Features are: packaged or compact substations are fully compartmentalized substations kept inside a prefabricated enclosure with MV switchgear, transformer, and LV switchgear; their compact substations are specially designed with the highest possible standards for personnel safety and a suitable ventilation system to suit local climatic conditions; and the enclosure of the CSS is manufactured using high-quality pre-galvanized sheet steel. This provides high resistance to corrosion, which is paramount in outdoor applications; its features include: transformers from 200 kVA to 3 MVA; extensible and non-extensible type MV switch gears up to 33 kV; LV ACB and MCCB feeder pillars and cabinets; automation and monitoring systems. The company, a high-tech manufacturing unit is engaged in R&D, production, and manufacturing of low and medium voltage switchgear.



Contact:

**Excel Power Switchgear Pvt Ltd**  
**15 First Street, Gandhi Nagar, Achugam Nagar**  
**Ekkatuthangal, Chennai 600 032**  
**☎ 044 – 2225 4870 • E-mail: sales@excelpower.co.in**



## Screw Conveyors

Screw Conveyor is among the simplest and most versatile type of Material Handling Equipment. MASYC offers – Standard Pitch, Short Pitch, Variable Pitch, Double Flight, Tapered Flight and Ribbon Flight Screw Conveyors to suit various applications. The Screw Flights are formed on the hydraulic press so as to maintain accurately the screw dia, pitch and the helix angle. Single Shaft, Double Shaft Paddle Conveyor mixers are also available. Screw conveyors handling highly abrasive material can be designed without hanger bearings up to the length of 12 m. MASYC an ISO 9001: 2000 Company has a formidable presence in the market in Bulk Material Handling Systems and Equipments. They have more than 30 yrs. of experience in turnkey execution of Bulk Material Handling Systems. Their products range of various conveying systems and equipment suit and match all the requirements in different processing industries like Cement, Steel, Coal, Pulp and Paper, Glass, Fertilizers, Mining, Power, etc.



Contact:

**MASYC Projects Pvt Ltd**  
 23 Community Center, Mayapuri Phase-I, New Delhi 110 064  
 ☎ 011 – 2811 5745, 2811 5453 • Fax: 011 – 2811 6850  
 E-mail: [masyc@masycproject.com](mailto:masyc@masycproject.com)

## Vertical Multistage Pumps

Shree-Laxmi offers Vertical Multistage Pumps. Features: Stainless steel construction and the conventional cast iron bases. Applications include: water distribution and pressurisation, boiler feed, irrigation and water treatment. The Company also offers Thermic Air Cooled Pumps with Mechanical Seal. These hot water or thermal oil pumps are particularly suitable for use in heat transfer systems or for hot water circulation. They are the ideal choice for handling mineral-based and synthetic heat transfer fluids. Shree-Laxmi's products range includes: Globe Valves, Blow Down Valves, Safety Valves; Boiler Chemicals, Industrial Boilers, Liquid/Gas Fuel and Solid Fuel Hot Water Generators, Hot Air Generators, Liquid/Gas Fuel and Solid Fuel Thermic Fluid Heaters, Industrial Autoclaves, Shell and Tube Type Heat Exchangers, Jacketed, and Limpeted Reactors, Pressure Vessels and SS/MS Tanks, Deaerator Tanks, etc.



Contact:

**Shree-Laxmi Engineering Private Limited**  
 Plot No: B-87 & 39/40, STICE, Musalgaon, Tal: Sinnar,  
 Nashik, Maharashtra 422 112  
 ☎ 0251 – 240 361, 240 042 • E-mail: [varpe@shreelaxmipl.com](mailto:varpe@shreelaxmipl.com)

## Direct Drive Pump

Over three decades of expertise in vacuum technology, Toshniwal Instruments (Madras) offers customized solutions ranging from individual products to a complete system. Toshniwal's Direct Drive high Vacuum Pump, the 72-D Series double stage model is with ultimate vacuum. This vacuum pump is compact, since it is directly mounted on motor flange. The pump has pumping speeds and high water vapour tolerance. The Oil consumption is extremely low and air cooled. 72-D Series pump offers improvement in the areas of quieter operation, smaller size and easy maintenance. Range: 120 litre - 1000 litre/minute. Features include: Portable; highly reliable; Low noise operation; Double Stage pump; Compact and Sturdy design; Advanced lubricating system; Easy maintenance and usage.

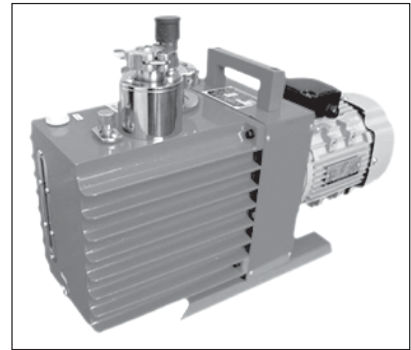

Contact:

**Toshniwal Instruments (Madras) Pvt Ltd**  
 267 Kilpauk Garden Road, Chennai 600 010  
 ☎ 044 – 2644 5626, 2644 8983  
 E-mail: [sales@toshniwal.net](mailto:sales@toshniwal.net)

	
<b>CHEMICAL PUMPS</b>	<b>GEAR PUMPS</b>
M.O.C. : SS316/Polypropylene	For Oil & Chemicals
<b>SEAL-LESS MAGNETIC PUMPS</b>	M.O.C. : C.I. / S.S.
M.O.C. : SS316/PP Type : Non-Flameproof / Flameproof	
<b>BARREL PUMPS</b>	
M.O.C. : CI/SS/PP Type : HAND / POWER / AIR Operated (FLP)	<b>HYDRAULIC TEST PUMP - HAND OPERATED / MOTORISED / GAS CYLINDER STRETCH TEST PUMP</b>
	Also Self Priming Multistage Boiler Feed Pumps
<b>C. BOLE &amp; CO. ESTD. 1944</b>	
61, NARAYAN DHURU STREET, MUMBAI - 400 003	
* TEL.: (OFF.) : 2342 9641 / 2342 4350 * FAX: 2342 4040	
* WORKS : 2578 3400 * FAX : 2578 3809	
* E-MAIL : <a href="mailto:cboleco@yahoo.com">cboleco@yahoo.com</a> / <a href="mailto:cbole@cboleco.com">cbole@cboleco.com</a>	
* WEBSITE : <a href="http://www.cbolepumps.com">www.cbolepumps.com</a>	

## Electrical Insulation Rubber Matting

Zenith Rubber manufactures Electrical Insulation Rubber Matting as per IEC 61111:2009, BS 921, AS 2978, ASTM-D 178, and IS 5424. Also known as electrical safety matting or switchboard matting is a specialized type of rubber matting designed to provide electrical insulation and protection against electric shock in various industrial and commercial settings. It is primarily used in areas where workers may come into



contact with high voltage electrical equipment or live electrical circuits. Electrical insulation mats are tested up to 60,000 volts in Zenith's in-house facility. Each roll is thoroughly tested as per specifications, ensuring complete safety with clear markings of test standards. Tough and long-lasting mats are designed to protect operatives from electrical shops. Easy to clean and maintain. It is available in several designs and colours for aesthetic appeal. Zenith Industrial Rubber Products Private Limited has been a leading manufacturer and exporter of high-quality industrial rubber sheeting products since its establishment in 1965. Over the years, Zenith has achieved remarkable success in the global market and has become recognized as a trusted supplier. Zenith offers a diverse range of products including wear-resistant rubber sheets, antiskid flooring, waterproofing membranes, coated fabrics, rubber inflatables, rubber moulded and extruded profiles. With an installed capacity of 90 tons of rubber compound per day, Zenith continues to strengthen its position in both domestic and international markets. Through its extensive experience, leadership, and dedication to quality, Zenith has earned a reputation as a reliable and trusted provider in the industrial rubber sheet manufacturing industry.

Contact:

**Zenith Industrial Rubber Products Pvt Ltd**  
140/144 Free Press House, Free Press Journal Marg  
215 Nariman Point, Mumbai 400 021  
☎ 0221 – 2288 5888, 6143 6500  
E-mail: [infor@zenithrubber.com](mailto:infor@zenithrubber.com)

## Specialised Cables

Udey Pyrocables manufactures and exports Specialised Cables like: Instrumentation Cables, RTD Cables, LiYY, LiYCY Cables, Foundation Fieldbus Cables, Profibus Cables, RS 485 MODBUS Cables, CAT 52, CAT 6, CAT 7 Cables, Fibre Optic Cables, Jelly Filled Telephone Cables, Control and Power Cables, Flexible Cables, Fire Alarm Cables, etc.

Contact:

**Udey Pyrocables Pvt Ltd**  
113 Shreepal Complex, Suren Road  
Andheri East, Mumbai 400 093  
☎ 022 – 2683 7565 / 2683 2117 • E-mail: [sales@udey.com](mailto:sales@udey.com)

## Sludge Pump System, Smartec

Schwing Stetter India Private Limited offers Smartec Sludge Pump System. If dewatered sewage sludge, organic waste or industrial and kitchen waste should be pumped economically and reliably, the Smartec sludge pumps from Schwing are the right choice. It offers high performance, exceptional reliability and an attractive price-performance ratio, and low maintenance costs. Technical data: Performance – Output: 1.0-12.0 m<sup>3</sup>/hr; Output pressure: 40 bar (non-stop operation); Design pressure max: 120 bar; Strokes max: 1.5-17.5 l/min; Driving power: 30 kW. Pump kit – Delivery cylinder: 180 x 500 mm; Differential cylinder: 90/50-500 mm; Delivery cylinder volume: 12.72 dm<sup>3</sup>/l; Valve system: Poppet valves or ROCK valve; Suction valve opening: 125 mm (with poppet valves); Pressure valve opening: 100 mm (with poppet valves); Pressure outlet: DN (with poppet valves); Grain size max: 20 mm (with poppet valves). Dimensions (sludge pump, single screw feeder and power pack mounted on base frame) – Length: 4535 mm; Width: 1350 mm; Height: 1535 mm; and Machine weight: 2,700/6,065 kg/lb.

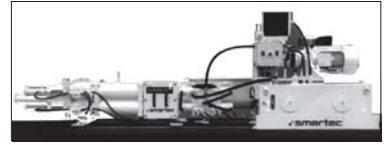

Contact:

**Schwing Stetter India Private Limited**  
F71/72 SIPCOT Industrial Estate, Irungattukottai  
Sriperumbudur, Kanchipuram Dist, Tamil Nadu 602 117  
☎ 044 – 7137 8100 / 7137 8101  
E-mail: [enquiry@schwingstetterindia.com](mailto:enquiry@schwingstetterindia.com)

## Kewaunee Flammable Storage Cabinets

Kewaunee Labway India's Flammable Storage Cabinets ensure maximum protection for both personnel and products. They are specifically designed for the storage of flammable and combustible liquids. The cabinets are designed in accordance with NFPA (National Fire Protection Association), OSHA (Occupational Safety and Health Administration) and FM (Factory Mutual International) regulations. Cabinets are available in a full range of sizes and designs including manual close, self-closing and bi-fold self-closing doors. 15 different capacities; three door options; Factory Mutual approved; Upper and lower diametrically; and Opposed side vents.

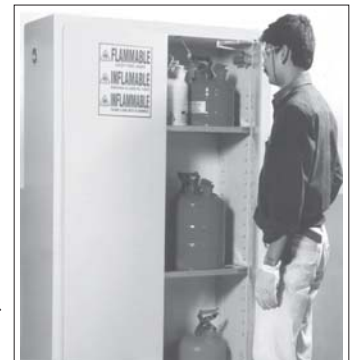

Contact:

**Kewaunee Labway India Pvt Ltd**  
2<sup>nd</sup> Floor, Tower-1, West Wing, E-City Software Park  
Symbiosis-CGI Road, Electronics City Phase 1  
Bengaluru, Karnataka 560 100  
☎ 080 – 6192 0000  
E-mail: [marketing@kewaunee.in](mailto:marketing@kewaunee.in)

## Industrial Valves

UNP Polyvalves is a leading manufacturer of various types of corrosion free valves, pipes and pipe fittings produced in advanced engineering plastics. The range includes: ball valves, butterfly valves, ball check valves, foot valves, sight glass, sampling, strainers, lined valves, etc. These valves are made out of polypropylene, HHS isotactic PP, PVDF, ETFE (Tefzel); UPVC, CPVC. Fluoropolymer lined piping system made out of PTFE, PVDF, FEP, PFA, ETFE, ECTFE, etc.

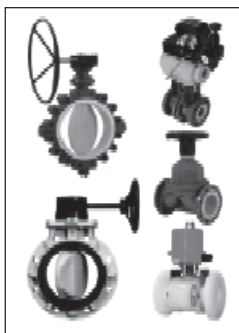

Contact:

**UNP Polyvalves (India) Pvt Ltd**  
**207 Orion Business Park, Next to Cine Max, Kapurbawdi**  
**Ghodbunder Road, Thane (W) 400 607**  
**☎ 022 – 2589 6422 • E-mail: mktg@polyvalve.com**

## Pneumatic Tools & Accessories

Ramsive Tools Pvt Ltd supplies a wide range of Pneumatic Tools and Accessories such as Impact Wrenches, Ratchet Wrenches; Impact Driver, Screw Driver; Air Drill, Spot Drill; Air Tapping, Micro Die Grinder, Air Die Grinder, Angle Die Grinder, Disc Grinder, Angle Grinder, Air Straight Grinder, Air Disc Grinder; Air Cut-off Tool, Surface Preparation Tool; Mini Air Sander, Air Polisher/Sander, Dual Action Sander, Orbital Palm Sander, Belt



Sander, High Speed Sander; Tyre Buffer; Air Hammer, Chipping Hammer, Hack Hammer; Riveter, Pop Riveter, Hydraulic Nut Riveter, Air Riveter; Weld Flux Chipper, Air Flux Chipper; Needle Scaler; Palm Nailer; Pneumatic Breaker; Mini Bench Rammer, Bench Rammer, Floor Rammer; Suction Gun Kit, Air Caulking Gun; Air Nibbler; Air Nipper; Engineering Tool; Air Knife, Air Shear; Air Saw Filer, Air Filer, Air Flat Filer; Air Valve Lapper; Pop Riveting Kit; etc.

Contact:

**Ramsive Tools Pvt Ltd**  
**S F No: 412, Texpark Road, Nehru Nagar, Sitra**  
**Coimbatore, Tamil Nadu 641 014**  
**☎ 0422 – 290 5003 • Mob: 90470 23253**  
**E-mail: info@ramsvetools.com**

## Pneumatic Products

ACE Flow Konzepts Pvt Ltd, an ISO 9001: 2015 Certified Company manufactures different range of Pneumatic Products for different applications. The products range are: Air Nozzles, Air Blowguns, Air Flow Vac; Air Wipes, Vortex Tubes, Machine Tool Cooler; Air Amplifier, Hand Vacuum Gun, Cabinet Cooler; Air Jets, Air Knife, Pneumatics Piston Vibrator, etc. Applications: Blowing; Drying; Cleaning; Cooling; and Material Flow. The Company has tie-up with AIRMASTERS, Spain and NAVCO, USA.



Contact:

**ACE Flow Konzepts Pvt Ltd**  
**68A, New Empire Industrial Estate, Kondivita Lane**  
**J B Nagar, Andheri (East), Mumbai 400 059**  
**☎ 022 – 4973 8514, 2834 2079 • Mob: 88283 33947**  
**E-mail: info@aceflow.co.in**

## Rotary Gear Pump

C Bole & Co offers a positive displacement Rotary Gear Pump for handling oil and other semi viscous liquids. The pump finds application for furnace oils, fuel oils, molasses, paints and pigments, castor oils, gasoline, inks, gums, sizing liquids, glue, polymers, cooking oils, glucose, sizing starch, colour feeding, tar, bitumen, thermic fluid, cryogenic liquid transfer, soap stocks/solutions, acid

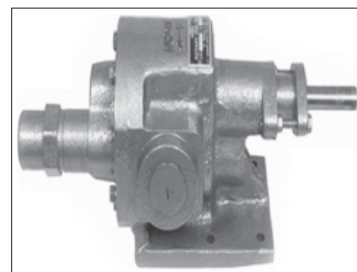

slurries, caustic lye, turpentine, varnish etc. This pump can be also used in applications like pressure feeding of fuel in burners, circulation of lube oils in gearboxes, turbines, fluid couplings, compressors, diesel engines, etc. Gear pump is available in SS316 construction incorporated with steam jacketed construction suitable for corrosive resins. Pump can also be supplied in gun metal, bronze construction with heating/cooling jackets; and with special mechanical seal, which prevents leakage near shaft end. The pump body is made of 2-piece type, i.e, only one joint in the body, which reduces the maintenance cost. It has easily replaceable bushes with positive lubrication arrangements. For handling all kinds of oils and other similar corrosive viscous liquids, pumps are supplied in CIMS construction. For viscous corrosive liquids and chemicals, pumps can be supplied in SS, gun metal or bronze construction with helical gears.

Contact:

**C Bole & Co**  
**61 Narayan Dhuru Street, Mumbai 400 002**  
**☎ 022 – 2342 4350 • Mob: 93200 99988**  
**E-mail: cboleco@yahoo.com**

## Hydraulic Self-Centering Steady Rest

Hydraulic Self Centering Steady Rest for crank shaft machining is a very important variant of steady rests. FAR has developed and supplied the entire range of steady rests required for crank shaft machining applications such as motor car to heavy railway and marine crank shafts. FAR have 2 different types of Self centering steady rests for crank shaft machining. The KRHS Series is a steady rest designed for crankshaft machining with rear mounted hydraulic cylinder with narrow arms. FAR can supply steady rest with provision for coolant flush through arms. The KRSHS Series is a steady rest designed for crankshaft machining with side mounted hydraulic cylinder with narrow arms. These steady rest are used on machines where the rear mounted cylinder may interfere with the door. FAR can supply steady rest with provision for coolant flush through arms. Fenwick And Ravi, an ISO 9001: 2015 Company is a Bangalore (Karnataka) based manufacturing company that brings forth a superior range of industrial products; and serve as a dependable manufacturer, exporter and supplier of Turning HSR, Grinding HSR, Bar Feeder, Mask Making Machine, Angle Heads, Material Handling Machine and many more



Contact:

**Fenwick And Ravi**

#10/3, Lakshimpura Main Road, Chikkabanvara PO  
Abbigere, Off Jalahalli West, Bengaluru, Karnataka 560 090

☎ 080 – 2325 4935, 2325 3901

Mob: 63645 81095 / 97317 11955

E-mail: anirudhravi@far.co.in

## Pressure Booster Pumps, SCM Series

Shakti Pumps (I) Ltd offers Pressure Booster Pumps SCM Series. Features: Compact design; Worldwide usage; High reliability; Easy to service and install; Silent operation; Wide performance range; Full stainless steel design; Booster sets for domestic water supply; Automatic start/stop when equipped with press control or pressure tank. Performance: Head – Max 125 m; Flow – 6 m<sup>3</sup>/hr; Discharge: Max 100 LPM; and Rating: 0.5 HP to 5 HP. Applications: Suitable for liquid transfer; Small industrial water supply systems; Washing systems; HVAC; Water treatment systems; Fire fighting systems; Industrial plants; Boiler feed systems; Pressure boosting systems; Domestic Water supply; and Horticultural irrigation systems.



Contact:

**Shakti Pumps (I) Ltd**

Sector-3, Pithampur, Dist: Dhar, Madhya Pradesh 454 774

☎ 07292 – 410500 • E-mail: info@shaktipumps.com

## Incremental Rotary Encoders

Givi Misure offers Incremental Rotary Encoders. Features: Incremental rotary encoder, based on optical principle; Small overall dimensions for applications with limited installation space; Wide range of pulses per revolution up to 64,000 ppr; Bidirectional signals with zero references, TTL; Output by connector or cable, radial or axial position; Aluminium flange and body; High-protection ring; High accuracy and stability of signals; Output by connector or cable, radial or axial position; and High accuracy and stability of signals. The Company's products range includes: Optical Scales, Magnetic Systems, Digital Readouts, Position Controllers, Incremental Optical Scales for Machine Tools, Magnetic Scales and Transducer MP/MTS, etc,



Contact:

**Givi Misure Pvt Ltd**

Plot No: 488, VITC Export Bhavan, KIADB Complex  
14<sup>th</sup> Cross, IV Phase Peenya Industrial Area  
Bengaluru, Karnataka 560 058

☎ 080 – 4127 2559 • Mob: 99000 28661

E-mail: info@givimidureindia.com

## Butterfly Valves

Maruti Industries offers Butterfly Valves with Electropneumatic Positioner, Butterfly Valve with Pneumatic Actuator, Lever Operated Butterfly Valve, and Gear Operated Butterfly Valve. Technical Data – Manufacturing Standard: ISO 5752/BS5155/API 609/IS 13095; Inspection and Testing Std: BS 6755 (Part-1)/API 598/EN 12266-1; End Connection: Wafer to suit ANSI B16.5 150#/ANSI 125#; BS to Tab D&E/IS 6392 NP 0.6/1.0/1.6; Face to face: BS 5155/ISO 5752/API 609; Top Flange Drilling: ISO 5211. The Company's products range includes: IC Knife Edge Gate Valve, Knife Edge Gate Valve with Pneumatic Operating, and Manual operating.



Contact:

**Maruti Industries**

119 Vikas Est, Nr: Municipal School, Anil Starch Mill Road  
Bapunagar, Ahmedabad, Gujarat 380 024

Mob: 99044 66842 / 98983 74361

E-mail: marutivalves@yahoo.com

## Hydraulic and LPG Hoses

S S Hydraulics (India) Pvt Ltd offers Hydraulic and LPG Hoses. Their products range includes: Hydraulic Male Female Adaptor, Hydraulic Gauge Adaptor, Hydraulic Reducer Bush, Hydraulic Weld Nipple, Hydraulic Weld Adapt-



er, Hydraulic Female Couplings, Hydraulic Unequal Union, Hydraulic Female Tee, Hydraulic MSC Adaptor, Hydraulic

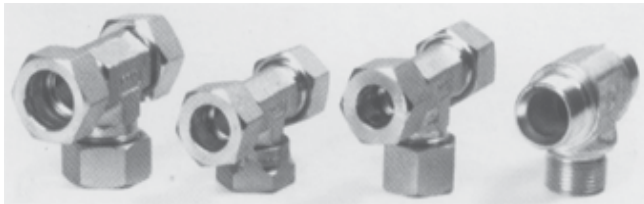

Equal Tee, Hydraulic Hose Fittings, Hydraulic Equal Union, Hydraulic Male Elbow, Hydraulic Banjo Couplings, Hy-



draulic Bulkhead Adaptor, Hydraulic Nut And Ferrule, Hydraulic UNF Adaptor, Hydraulic Hex Nipple, Hydraulic



Male/Female Tee, Hydraulic Swivel Elbow, Hydraulic Cone Plug, Hydraulic Elbow, Union, Tee And Bulk Head Assemblies; Gas Regulators; Twin Stream Pressure Reducing System, Two-stage Pressure Reducing System, etc.

Contact:

**SS Hydraulics (India) Pvt Ltd**  
No: 187, Linghi Chetty Street, 1<sup>st</sup> Floor  
Parrys, Chennai 600 001  
☎ 044 – 2522 0576, 4774 1046 • Mob: 91285 15253  
E-mail: sshydraulics2018@gmail.com

## Air Driven Liquid Pumps

Sealing Tech Inc offers Air Driven Liquid Pumps, which are suitable for different flow rates as well as for different operating pressures. Media – water, oil and gas. Max Operating pressures up to 7000 bar (101,000 psi). Applications: Lifting and Clamping, Hydraulic applications, Burst and Cycle fatigue testing, Leak testing, Pressurization.

Contact:

**Sealing Tech Inc**  
17 St Thomas St, Santhosh Nagar, Kandanchavadi  
Chennai 600 096  
☎ 044 – 2496 1336 • Mob: 72000 73285  
E-mail: mail@sealingtech.in

## Flow Switches

Arbuda offers Flow Switches. The paddle type flow controllers are specifically designed for use on liquid lines such as water, ethylene or any other fluid which is not harmful to brass or phosphor bronze and which is not classified as a hazardous fluid.

Features – MOC: Brass/Phosphor Bronze/SS; Max Operating Pressure: 10 bar/140 psi;

Media temperature: 1 to 100°C; and Flow rate: M3.

Contact:

**Arbuda Instruments**  
E-11/1 GIDC, Sector 26, Gandhinagar, Gujarat 382 026  
Telefax: 079 – 2328 7990  
Mob: 90337 11390 • E-mail: arbudainst@yahoo.com



## Phosphorous Chemicals

Prasol Chemicals Pvt Ltd supplies Phosphorous Chemicals – Phosphorus Acid Crystals; Sodium Hypophosphite; Hypo phosphorous Acid; Phosphoric Acid Fluid Grade 85%, 88%; Tetrakis Hydroxymethyl Phosphonium Sulphate (THPS); Red Phosphorus; Yellow Phosphorus; Perchloric Acid 60%, 70%. Also offers Organic Chemicals, Phosphorous Based Products, Speciality and Performance Chemicals, Resins/Polymers, Amines, etc.

Contact:

**Prasol Chemicals Pvt Ltd**  
Prasol House, Plot No: A-17/2/3, TTC Industrial Area  
Khairne MIDC, Navi Mumbai 400 710  
☎ 022 – 6195 2500 • E-mail: inquiry@prasolchem.com

## HDA Series Mounts

HiDamp's HDA Series Hidamp adapter mounts are designed to withstand the rigors of heavy duty on road/off mobile applications and in construction equipments. Usage in machinery, pumps and compressors.

Contact:

**HiDamp Industrial Mountings Pvt Limited**  
Hidamp Gardens, Vedapatti, Coimbatore, Tamil Nadu 641 007  
☎ 0422 – 653 2118 • Mob: 94897 53070  
E-mail: hidamp@hotmail.com

## Industrial Ventilation Coolers

SRE Corporation offers Industrial Ventilation Coolers. Salient Features: Water Evaporative Humidifiers; Temperature Reduction; Environment Friendly; High Efficiency; Quali-



ty Service; Maintenance is easy; Corrosion resistant; Best Service back-up, Warranty package; Absorb Heat when hot air goes through the cooling pad; Prevent from diseases and creates healthy surroundings; Shed away the polluted air with dust and odour; Low investment and minimum running cost; Good water absorbing and ventilating performance. Cool Air Alternative to Ceiling/Wall Mounted/Pedestal Fans, which rotates only stale and hit air. Coolers used in Textile and various industries; Commercial and Industrial Sector, Office Rooms, Residential areas, Industrial Kitchens, Departmental Stores, Hospitals, Vegetable shops, Shopping malls, Educational institutions, Gyms, Green house, Hotels and resorts, Indore stadiums, Browsing centres, Coffee shops, and Worship places, etc.

Contact:

### SRE Corporation

358 Tank Road, Balaji Nagar, Opp: Ulavar Santhai, Singanallur, Coimbatore, Tamil Nadu 641 005  
Mob: 97876 76494 / 99437 86494 • E-mail: sretex@gmail.com

## Pipes & Fittings

Sarda Piping Systems (SPS) is engaged in the field of Piping engineering and fabrication. SPS primarily caters to National and Multinational OEMs of power generation equipment, engineering, procurement and construction (EPC) contractors serving Power Generation, Oil and Gas, Refinery/Petrochemicals, Nuclear, Process, Shipping, Sugar, Cement and others.



The Company's products range includes: High pressure piping systems, Induction Pipe Bends, Pipe Fittings, Hanger and Support, Butt Weld Pipe Fittings, Socket Weld/Threaded Pipe Fittings, Flanges. SPS offers wide range of engineering services for advance piping solutions. Applications: Petroleum and Natural Gas Projects, Petrochemicals Projects, Sugar and Cement industries projects, Boiler Industries, Marine/Offshore Projects, Process Plant projects, Power Plant projects, etc..

Contact:

### Sarda Pipes & Fittings Pvt Ltd

103 Shreeji Chamber, Tata Road No: 2  
Opera House, Mumbai 400 004  
☎ 022 – 4974 2728, 4974 2729 • E-mail: info@spiping.in

## Valve Manifolds

Star-Mech Controls (India) Pvt Ltd offers Valve Manifolds like Bar Stock Needle Valve. It is a hand operated valve for isolation of medium, with a variety of inlet and outlet connections. Two Valve

Manifold: A two valve manifold combines facilities for isolation, calibration, test and venting of the instrument. This manifold is generally used with pressure gauges, transmitters, pressure switches and similar pressure measurement equipment.



The manifold is available in number of configurations to suit every type of installation. A variety of mounting/support methods are possible; For Line installation and suitable for wall mounting using two M8 bolts. Three Valve Manifolds: A three valve manifold is used in conjunction with differential pressure transmitter. It provides two isolation, equalizing and drain/test functions. It allows the operator to isolate, zero adjust the instrument and safely drain any trapped medium. The drain ports have dual functions. They can also be used as test or calibrations after the draining operation.

Contact:

### Star-Mech Controls (India) Pvt Ltd

Sushilottam, 29/3A/3 Sasanenagar, Hadapsar  
Pune, Maharashtra 411 028  
☎ 020 – 2697 0440 • Mob: 99229 57538  
E-mail: marketing@starmech.net

## Non-Destructive Headspace Oxygen Analyzer

Skytech Systems (India) Pvt Ltd offers Non-Destructive Headspace Oxygen Analyzer from Gasporox, Sweden. It has developed and commercialized the tuneable diode laser absorption spectroscopy (TDLAS) technology, offering an effective and fast gas measurement for quality assurance packages in



pharmaceutical, food and beverage industries. The method is recommended by <USP1207>. The Headspace Oxygen Analyzer is for Oxygen measurements of parental pharmaceutical in vials/ampules or pouches/IV bags. The instrument has standard 2R-100R and customized format parts that cover a wide range of vial sizes. The measurement of oxygen headspace can be performed on primary or secondary bag without the loss of the bag or its content along with 21 CFR compliance software.

Contact:

### Skytech Systems (India) Pvt Ltd

403 4<sup>th</sup> Floor, Siddheshwar Arcade, Ghodbunder Road  
Opp: Suraj Water Park, Waghbil  
Thane (West), Maharashtra 400 615  
☎ 022 – 4153 3342 • Mob: 93232 00808  
E-mail: marketing@skytechindia.com

## Submersible Pumps

Mody Pumps (India) Pvt Ltd supplies a range of Submersible Pumps. The range includes: Wastewater, Sewage and Sludge Series – Equipped with high efficiency motors, Class H insulation and VFD with an optional self-contained maintenance free cooling system. Available from 3.7 kW to 200 kW. Grinder Series – Features adjustable duplex stainless steel grinding mechanism and high efficiency motors, Class H insulation and VFD rated. Available 13.5 kW. Sewage Handling Series – Dimensionally interchangeable with other popular pump brands. Ideal for portable and permanent applications. Units can handle Solids up to 100 mm and 15 starts/stops per hour. Available up to 90 kW. Slurry and Sand Series – Designed to handle highly abrasive particles in suspension. Hi-Chrome dual impellers provide maximum solids handling without sacrificing efficiency. Available up to 112 kW. Dewatering Slurry and Sand Series – these units feature 28% Hi-Chrome components with a built-in agitator and designed for portable installations. Available up to 37 kW. Air Operated Double Diaphragm Series – Portable Double Diaphragm pumps for various application in Chemical, Construction, Mining, Utility, Process, Refineries, Textiles, Pharmaceuticals, Ceramic, Foods and Beverages industries. Ranging from ½” to 3” Inlet/Outlet. Design and MOC available for various applications.



Contact:

**Mody Pumps (India) Pvt Ltd**  
N-65 Anand Nagar, Additional MIDC, Ambernath East  
Dist: Thane, Maharashtra 421 506  
Mob: 91687 52221 • E-mail: [indiasales@modypump.com](mailto:indiasales@modypump.com)

## Silica Fume (Micro Silica)

Valco Concrete Plus Limited of Hong Kong supplies Silica Fume (Micro Silica). It is a by-product of producing silicon metal or ferrosilicon alloys, it is an ultrafine material with spherical particles less than 1 um in diameter, the average being about 0.15 um. This makes it approximately 100 times smaller than the average cement particle. The specific gravity of silica fume is generally in the range of 2.2 to 2.3. The specific surface area of silica fume can be measured with the BET method or nitrogen adsorption method. It typically ranges from 15,000 to 30,000 m<sup>2</sup>/kg. Because of its extreme fineness and high silica content silica fume, is a very effective pozzolanic material on concrete production.

Contact:

**Valo Concrete Plus Limited**  
Room 18, 7/F Ming Sang Industrial Building 19-21 Hing Yip  
Street Kwun Tong Kowloon, Hong Kong  
☎ +85269332060 • E-mail: [info@valoconplus.com](mailto:info@valoconplus.com)

## Flat Submersible Cables (3-Core)

Empire Cable Industries Pvt Ltd manufactures a wide range of electrical PVC insulated wires and cables, which are used by quality conscious electrical contractors and recommended by leading consultants, architects, builders for projects, domestic, industrial and agricultural wiring for trouble free working. The connecting cables are used for submersible pump motors. These cables are manufactured keeping in mind the severe and difficult conditions in which they are required to perform. The individual conductors are made from bright electrolytic grade copper; and drawn, annealed and bunched properly to ensure flexibility and uniform resistance. Each of the 3 copper conductors is insulated with special PVC compound. The cores are laid up in flat parallel position. The outer sheath of the cable is made from a special grade of abrasion resistance PVC compound impervious to water, grease, oil, etc.



Contact:

**Empire Cables Industries Pvt Ltd**  
115 Phase II, Badli Industrial Area, Delhi 110 042  
☎ 011 – 2789 3424, 2386 8832  
E-mail: [empirecables@yahoo.co.in](mailto:empirecables@yahoo.co.in)

## Vacuum Pumps

PPI Pumps, an ISO 9001: 2008 certified company, and is one of India's largest vacuum pumps manufacturers. They offer a range of vacuum pumps in different sizes and capacities:

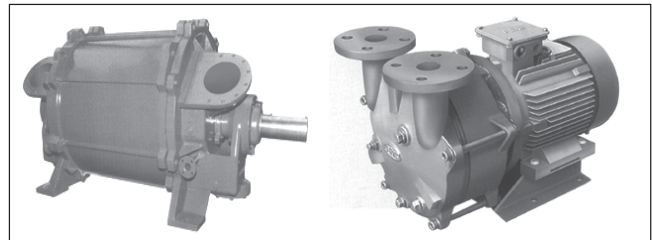

Close Couple Vacuum Pump CC Series (pix, left) – Suction capacity: 20 to 200 m<sup>3</sup>/hr; Power consumption: 0.75 kW to 5.5 kW; Maximum vacuum: 700 mm of Hg (G). Used in plastic industries and breweries. PRV Series Liquid Ring Vacuum Pump – Suction capacity: 7200 to 16000 m<sup>3</sup>/hr; Power consumption: 110 kW to 500 kW; Maximum vacuum: 700 mm of Hg (9G); widely used in Pulp and paper industries, and Sugar mills.

Contact:

**PPI Pumps Pvt Ltd**  
14 & 16 C, Phase 1, GIDC Estate, Vatva  
Ahmedabad, Gujarat 382 445  
☎ 079 – 2583 2274, 3251 6741 • E-mail: [sales@ppipumps.com](mailto:sales@ppipumps.com)

Visit us at: [www.ips.co.in](http://www.ips.co.in)

## Pneumatic Cylinders

Aircon Pneumatics offers Pneumatic Cylinders: Compact Block Cylinders – Bore: 25, 32, 40, 50, 63 mm; Stroke: 5 to 50 mm; Mounting: Front Flange, Leg, Direct; Pressure: 0-10 bar. Telescopic Cylinders – Bore: 40, 50, 63, 80, 100, 125, 150, 200 mm; Type: Single Acting, Double Acting; Stroke: Up to 10000 mm; Mounting: R.F, F.F, R.T, S.T; Pressure: 0-

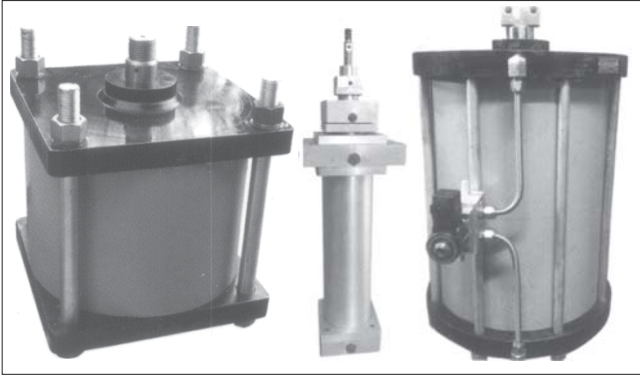

10 bar (high pressure on request); MOC: Aluminium, SS-304/316. Special Application Cylinders Double Ended, Tandem, Impact – Bore: 40, 50, 63, 80, 100, 125, 150, 200 mm. The Company's products range includes: Hydraulic Cylinders, Special SS Cylinders, Special Heavy Duty Cylinders, Hydraulic Rotary Actuators; Solenoid Valves – Direct Acting; Pilot Operated Poppet Type; Direction Control Valves; Spool Valves, Auto Drain Valves, System Valves with Actuator, Butterfly Valves with Rotary Actuator, Pneumatically Actuated Knife Gate Valves, Linear Air Motors, etc.

Contact:

**Aircon Pneumatics**  
F-30/29/27 MIDC, Phase-II, Dombivli (East)  
Dist: Thane, Maharashtra 421 204  
Tel: 0251 – 657 0919 /287 0024  
E-mail: airconpneumatics@gmail.com

## Dyes, Pigments & Textile Chemical

Gujarat Polysol Chemicals Limited, an ISO (9001/14001) Certified Company, and one of India's leading manufacturers of a wide range of chemicals and intermediates that are aimed to meet the challenges of the current global lifestyle. The Company manufactures and supplies Dyes, Pigments and Textile Chemicals – Dispersing agent based on Sulphonated Naphthalene formaldehyde condensate; wetting cum dispersing agent based on Sulphonated Alkyl Naphthalene condensate; Wetting cum dispersing agent based on Sulphonated Alkyl aryl formaldehyde condensate; Wetting agent based on Alkyl ester Sulphonates. Infra-Tech Chemicals, Oil Field Chemicals, Leather Chemicals, Agro Chemicals, Textile Chemicals and Dispersing Agents for dyes.

Contact:

**Gujarat Polysol Chemicals Limited**  
Plot No: 1734, III Phase, GIDC, Vapi, Gujarat 396 195  
Mob: 98251 17532, 99259 90147 • E-mail: info@gpcpl.net

## Centrifugal Monoblock Pump

Toshio Technology Pvt Ltd offers Centrifugal Monoblock Pump. Its Features: Axial inlet and radial outlet; Single stage monoblock design; Dynamically balanced Rotor and Impeller; Pumps available with 2880 and 1450 rpm; Good quality Bearing. Technical Data – Flow Range: Up to 135 m<sup>3</sup>/min; Maximum Head: Up to 76 m; Liquid Temperature: Up to 40°C; Frequency: 50 Hz; MOC:



Cast Iron, SS304 and 316. Applications: Chillers, Gardening and Nurseries, Domestic Water Supply, High rise Buildings, Hotels and Hospitals, Agriculture, Irrigation, Drip and Sprinkler Systems. The Company is an STP/ETP Pumps and Aerator Specialist, and its products range includes: Submersible Vortex Sewage Pump in Different Series, Submersible Grinder Pump, Effluent Pumps, Drainage Pumps, Dredging Pumps, Submersible Mixer, etc.

Contact:

**Toshio Technology Pvt Ltd**  
Unit 1, 601/D, Wifi Park, Road No: 1, Above Satkar Grande  
Opp: Aplab Co, Wagle Indl Estate, MIDC  
Thane, Maharashtra 400 604  
☎ 022 – 2582 8400 • Mob: 91672 02692  
E-mail: sales@toshiotechnology.com

## Float Valves

Shridhan Automation Pvt Ltd offers Float Valves. A Float Valve is used to shut off the flow of liquids, normally water, at a pre-determined level. When adjusted and working



properly a float valve is very accurate and extremely reliable. Float valves are found in nearly many industrial applications. The concept of the float valve is very simple, which accounts for its reliability and wide spread use. Features: Proportional behaviour (the flow is inversely proportional to fluid level in the tank); Easy to install and maintain; Compact design. Applications: Liquid storage tanks, Sumps. The Company's products range includes: Rotary Paddle Level Switches, Bilge Level Sensors, Conductivity Type Level Switches, Magnetic Level Indicators, Float & Displacer Type Level Switches, Float Operated Level Transmitters, etc.

Contact:

**Shridhan Automation Pvt Ltd**  
No: B-54, KSSIDC Industrial Estate, Kumbalgotu  
Mysore Road, Bengaluru, Karnataka 560 074  
☎ 080 – 2843 7847, 2843 7848 • E-mail: info@shridhan.com



## AC to AC Solid State Relay

Unison Controls Pvt Ltd offers AC to AC Solid State Relay Model 901. Features – Input: 100-280 V AC/4-12 mA.

Input LED: Green. Output: 24-600 V AC (47-63 Hz); PIV: 800 or 1200 Vpk. Zero Cross Over. Product Temp withstands capacity: 150°C; Body Insulation: 8 kV for 1 min; I/P to O/P Insulation: 8 kV for 1 min; Flaps on I/P and O/P Terminals; Short Circuit Protection by B Curve and DP MCB; Short circuit Current Rating: 10 kA for < 3 mS. Available Amp range: 25, 40, 50, 90 and 200 Amp Load Current at 40°C with Heat Sink. The Company also offers Random Solid State Relay, DC to AC Solid State Relay, Phase Angle Control SSR, etc.



Contact:

**Unison Controls Pvt Ltd**  
165 A-D, Devraj Industrial Park, Piplaj-Pirana Road  
Piplaj Near 200 Feet SP Ring Road  
Kamod Cir, Ahmedabad, Gujarat 382 405  
Mob: 62627 00700  
E-mail: info@unisoncontrols.com

## Edge Protector Making Plant

K U Sodalamuthu And Co Pvt Ltd, an ISO 9001: 2008 Company, offers Sodaltch Edge Protector Making Plant is made heavy duty to produce high strength paper edge protec-

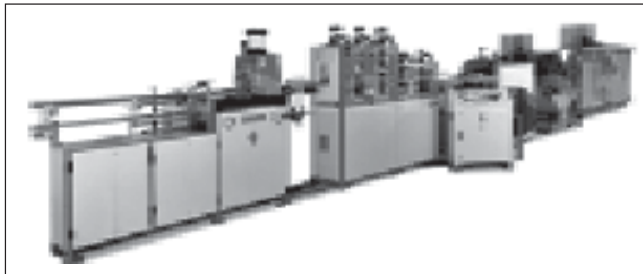

tors and 'U' Profile channels which are very ideal to prevent damages to edges of various palletized goods and circular goods like paper reels, steel coils etc. The machine is rugged, yet easy to use. It has facility to interchange profile design and variable speed drive for faster setting and control of process wastage. The future of packaging lies in the recyclability of most of the packaging materials. Edge protector is an environment-friendly product using strong paper board which is easily recycled. The use of edge protectors eliminates the damage to edges and corners in handling, warehousing and transport operations.

Contact:

**K U Sodalamuthu And Co Pvt Ltd**  
428 Mettupalayam Road,  
Coimbatore, Tamil Nadu 641 043  
☎ 244 1223 • E-mail: sales@sodaltch.net

## Solenoid Valve Connectors

M.Con Connectors manufactures Solenoid Valve Connectors conforming to DIN 43650 Standards. These Connectors are designed to provide easy and reliable quick disconnect options for many valve applications. The Versatile design allows for easy installation whether it is for a new industrial application or maintenance and repair. These quality solenoid valve connectors are available in field wire able models.



M.Con also offers connectors with a wide range of circuit-

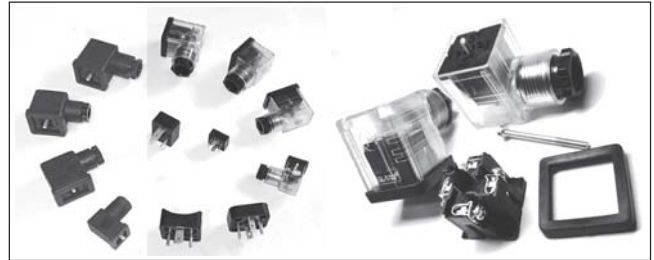

ry, including MOVs, Diodes, and Rectifiers, etc. M.Con DIN Connectors' applications include: Machine Building; Assembly with Hydraulic system; Pneumatics System In-

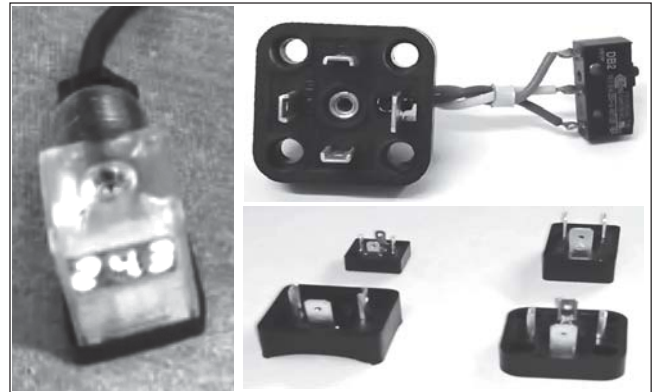

tegration; Material Handling equipment; Industrial Process Automations; Transportation; Electromagnetic devices and Sensors.

Contact:

**M.Con Connectors**  
Unit No: 212 & 216, A-Wing, Jai Estate, Opp: SBI Bank  
MIDC Phase-1, Dombivli, Dist: Thane, Maharashtra 421 203  
Mob: 72085 03012, 99303 94422 • E-mail: sales@mcon.co.in

## Specialty Chemicals

Prasol manufactures Specialty Chemicals. Their products range includes: Organic Chemicals; Phosphorous Based Products; Solvents; Phosphorous Chemicals; Specialty and Performance Chemicals; Resins/Polymers; etc.

Contact:

**Prasol Chemicals Pvt Ltd**  
Prasol House, Plot No: A-17/2/3, TTC Industrial Area  
Khairne MIDC, Navi Mumbai 400 710  
☎ 022 – 6195 2500 • E-mail: inquiry@prasolchem.com

## Hybrid Servo Hydraulic System

Advance Plastic supplies Hybrid Servo Hydraulic System. The system offers an alternative for applications requiring high performance and high reliability when the servo is the only choice, while it remains cost-effective.

The system includes a 3-phase stepper motor combined with a fully digital, high performance drive and an internal encoder, which is used to close the position, velocity and current loops in real time, just like servo systems. It combines the best of servo and stepper motor technologies, and delivers unique capabilities and enhancements over both, while at a fraction of the cost of a servo system. Benefits: Reduce the hydraulic oil usage; Energy saving rate between 30% and 80%; Pressure and Flow Double Loop Control; Increase product Mold cycle by 5%-10%; improve the machine reliability.

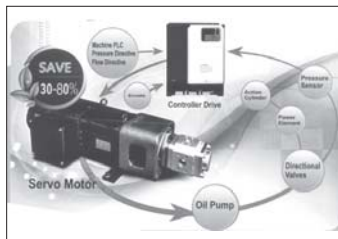

Contact:

**Advance Plastic Machinery**

**A-33, Sector-7, Noida, Dist: Gautam Budh Nagar  
Uttar Pradesh 201 301**

**Telefax: 0120 – 422 3993 • Mob: 98100 07993, 99101 01015**

**E-mail: [advancemoulder@yahoo.co.in](mailto:advancemoulder@yahoo.co.in)**

## Effluent Treatment Plant

WTE Infra Projects Pvt Ltd offers Effluent Treatment Plant. The Company is having technologies to treat wastewater generated from various industries containing highly organic, inorganic load, oil and grease, heavy metals and sus-



ended solids. Based on the effluent parameters as per nature and compositions, the Company designs steady state model to overcome environmental issues related to industry. The processes involved for the treatment of various effluents are anaerobic (UASBR, Anaerobic filter, biodegestor), aerobic (diffused aeration), hybrid (anaerobic + aerobic). Salient Features: Manual, Semi-Automatic and Fully Automatic; Type – Batch and Continuous, and Silent in operation. Applications: Sugar, Pharmaceutical, Electroplating; Dairies, Paper and Pulp, Automobile; Food processing, Chemical, Paint.

Contact:

**WTE Infra Projects Pvt Ltd**

**PAP-S-77, Nr: Bridgestone Company, MIDC Phase-II  
Sawardari Village, Chakan, Taluka Khed, Dist: Pune  
Maharashtra 410 501**

**Mob: 88888 89611 / 88888 89622 • E-mail: [enq@wteinfra.com](mailto:enq@wteinfra.com)**

## Teflon Lined Pumps

Alpha Techno-Chem Equipments & Services offers Teflon Lined Pumps, which are specially designed to handle a wide spectrum of highly corrosive media. It uses a hi-tech lining process, free from adhesive bonding. This eliminates peeling off of the lining from the metal body unlike other lined products. Rigorous quality checks throughout the lining process ensure years of trouble free operation. These pumps are available in a variety of lining materials to withstand severe corrosion and temperature conditions. Features: The hi-tech lining process involves high pressure molding at high temperature to ensure uniform thickness



of lining free from cavities, air pockets, cold flows, etc. A unique feature is the dove-tail grooves provided on the metal casing and back plate. This ensures a firm grip between the metal and lining material. A dynamically balanced, solid moulded, semi-open impeller with metallic insert gives mechanical strength and durability. These pumps are available with External Mechanical Seals, Internal Mechanical Seas as well as Gland Packing. Range – Capacities: 400 m<sup>3</sup>/hr; Head: 100 metre; Temperature: Up to 200°C.

Contact:

**Alpha Techno-Chem Equipments & Services**

**Unit No: 2, Gr Floor, Jai Estate, Plot No: 6, 6A, 6B**

**Opp: State Bank, Phase-1, MIDC Dombivli East**

**Dist: Thane, Maharashtra 421 204**

**Mob: 84228 84458 / 84228 84460**

**E-mail: [info@alphatechnochem.com](mailto:info@alphatechnochem.com)**

## Valves

Samson Controls Pvt Ltd, a 100% subsidiary of Samson AG Germany, manufactures and supplies Samson equipments such as Automated and non-automated valves for Control and On-Off function, Positioners (Conventional and Smart) self-operated pressure and temperature regulators, differential pressure type level gauges. Samson Controls provides engineering expertise for special engineered valves from Samson Group companies as well as others. Products range are: Check valves, Globe valves, Gate valves, Self-operated Pressure and Temperature Regulators, Positioners (Conventional and Smart), etc.

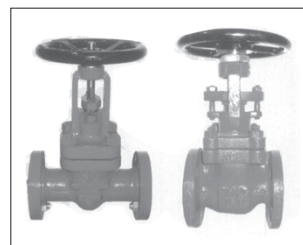

Contact:

**Samson Controls Pvt Ltd**

**604 P-3, Pentagon Building, Magarpatta City  
Hadapsar, Pune, Maharashtra 411 028**

**☎ 020 – 6724 6600**

**E-mail: [info@samsoncontrols.net](mailto:info@samsoncontrols.net)**

## Centrifugal Chemical Process Pump Match III

Jat Ambe Engineering Co is a manufacturer of Industrial Chemical Process Pumps and Valves. The Constructional Features: Pumps are as per ANSI B73-1M. The design is of back pull out type. Large varieties for models are available to operate at 1450 RPM and 2900 RPM at 50 Hz and 1750 RPM and 3500 RPM at 60 Hz. ANSI Series Chemical Process pump is a horizontal single stage centrifugal pump. Range – Delivery size: up to 200 mm (8" inch); Capacity: Up to 410 m<sup>3</sup>/hr; Head: Up to 150 m; Working Pressure: 17 kg/cm<sup>2</sup>. Applications: Acid Transfer, Beverage Processing, Brine, Chemical Processing, Chloral-alkali, Corrosive Services, Organic Chemicals, Polymer, Sea Water, Solvents, Paper, Food, Synthetic Fibers, Slurry and others.



Contact:

**Jat Ambe Engineering Co**  
1 Shree Jay Laxmi Industrial Estate, CMC Compound  
GIDC, Odhav, Ahmedabad, Gujarat 382 415  
☎ 079 – 2289 4562, 2287 4508  
E-mail: sales@jecwoodland.com

## Oil Free Diaphragm Type Vacuum Pressure Pumps

Promivac Pumps Pvt Ltd offers Oil Free Diaphragm Type Vacuum - Pressure Pumps. These are 100% oil-free, air cooled, wherein not even a single drop of oil is used and are a boon for vacuum and pressure applications, where even slightest environmental contamination through oil mist is forbidden. Also available with internal parts Teflon coated and complete polypropylene contact parts. Applications: Chemical Analysers, Pollution Control Equipments, Gas Monitoring, Nitrogen Generating Sets, Ozone Generators, Operating Clinical, Medical and Scientific Laboratory Equipments, Desoldering, Filtration, Dentistry and Spray Painting, etc. The Company's products range includes: Piston Type Dry Vacuum Pumps and Compressors, Mechanical Vacuum Boosting Systems, Rotary Vane Type Vacuum – Pressure Pumps, Direct Drive Rotary High Vacuum Pumps, Vacuum-Pressure Sludge Suction and Disposal Pumps, Centrifugal Blowers, etc.



Contact:

**Promivac Pumps Pvt Ltd**  
3575 Netaji Subhash Marg, Darya Ganj, New Delhi 110 002  
☎ 011 – 2328 1082, 2327 3965  
E-mail: info@promivacpump.com

## Automatic Hi-Speed Triple Head Container Filling Machine

Pharma Chem Machineries, manufacturers and exporters of Pharmaceutical, Cosmetic and Food Industrial Machinery offers Fully Automatic Hi-Speed Triple Head Container Filling Machine. Its Features: Fully automatic except turntable feeding; all parts are easy cleaning and sterilize; easy to operate and maintenance; filling range: 5 to 150 g in syringe / 5 to 150 g in container. The Company's products range includes:



Automatic Ointment/Cream Manufacturing Plant, Automatic twelve station laminated tube filling and sealing machine, Semi-Automatic twelve station laminated tube filling and sealing machine, semi-automatic eight station aluminium tube filling, crimping and batch coding machine, Automatic Empty Capsule loader, Capsule Hand Filling machine, Fully automatic Double Disc Counting machine, etc.

Contact:

**Pharma Chem Machineries**  
311/2484 Motilal Nagar No: 2, M G Road  
Goregaon (West), Mumbai 400 090  
Mob: 98694 42113 • E-mail: pharmach@gmail.com

## Precision Cold Forging/Cold Extrusion Hydraulic Presses, 4-Column Type

Abexmatic Hydraulics Pvt Ltd offers 4-Column Type Precision Cold Forging/Cold Extrusion Hydraulic Presses. The traditionally designed 4-column hydraulic presses with reinforced steel structure are made for cold forging precision auto/ industrial components in mass production with minimum rejection and maximum tool life through minimum deflection, optimum hydraulic circuit design and integrated control of manufacturing processes. Specification of Model ABXC-400 – Pressing capacity: 400 ton; Pull-out capacity: 30 ton; Table area LR x FB: 600 x 700 mm; Stroke: 500 mm; Daylight opening: 700 mm; Descending speed: 15-30 mm/sec; Ascending speed: 300 mm/sec; Intensifier capacity: 450 kg/cm<sup>2</sup>; Die cushion capacity: 40 ton; Cushion stroke: 150 mm; Motor: 50 HP.



Contact:

**Abexmatic Hydraulics Pvt Ltd**  
H131, Sector-4, DSIIDC Industrial Area  
Bawana, Delhi 110 039  
☎ 011 – 4554 7413 • Mob: 98101 30494  
E-mail: abexmatic@yahoo.co.in

## Hydraulic Fixture

Swift Engineering offers Hydraulic Fixtures. If the fixture used is automated in clamping or location then the fixture will be hydraulic fixture. The only difference between a

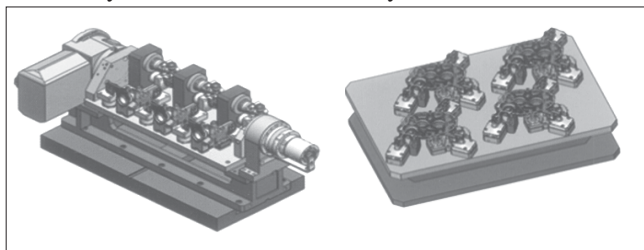

hydraulic and a manual fixture is that the location and the clamping will be done using hydraulic components. When hydraulic components are used to automate the fixture from its function then the fixture is known as hydraulic fix-

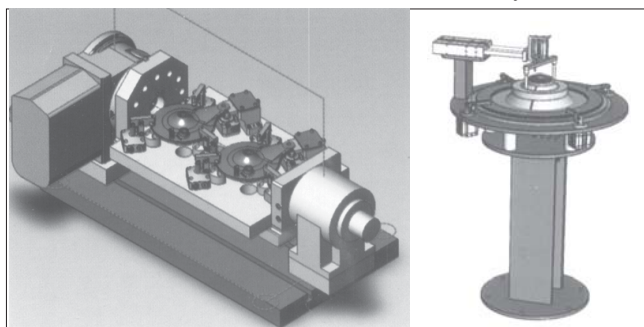

ture. Swift Engineering products custom work holding fixtures for all CNC applications including hydraulic work holding fixtures, manual work holding fixtures and pneumatic work holding fixtures. The Company manufactures quality work holding fixtures that work in the most challenging environments and applications imaginable.

Contact:

**Swift Engineering**  
7/4 Jaganathan Industrial Estate  
B/h: Chaitanya School, Chinnavedampatti  
Coimbatore, Tamil Nadu 641 040  
Mob: 97904 10037, 93605 03305  
E-mail: swiftengg.cbe@gmail.com

## Alkaline Based Descaling Chemical

Elite Aquachem manufactures Alkaline Based Descaling Chemical. Its applications: Mix the 6-10% of the concentrate in water thoroughly; Subject the solution to the temperature of 70-80°C; Dip the component in the solution for some time (10-15 minute), Preferably with tumbling action; Similarly, rinse with water and air dry the component. Benefits: Specialized product for the descaling; Dissolves the scales and removes the metallic deposits; Contains a blend of excellent oxidizing agent; Suited for ultrasonic machine.

Contact:

**Elite Aquachem**  
1&2 Sutirth, Sagar Signature, Waliv-Phata, Sativali  
Vasai (East), Dist: Palghar, Maharashtra 401 208  
Mob: 93200 03592 / 83697 73774  
E-mail: eliteaquachem21@gmail.com

## Submerged Sump Pumps for High Temperatures

Egger Pumps India Pvt Limited offers Submerged Sump Pumps for High Temperatures. Molten salt for heat transfer, hardening salt, liquid sulphur or hot slop must be pumped at temperatures between 150° and 450°C. These partly sluggish liquids are usually pumped from pressure-free containers. The temperature, pour point, solid matter, corrosive attack or high vapour pressures normally require sealless submerged sump pumps with customised design details. For safety reasons, a dry-installed pump is not recommended and problematic due to the sealing of the shaft. Egger's high pressure and temperature series is the solution. Egger has developed a special high temperature series for these kinds of applications. Depending on the application, the cantilever design (without bearing and without shaft sealing) or the high temperature submerged sump pumps are used. In the case of granulate media the temperature of both types can be adjusted.

Contact:

**Egger Pumps India Pvt Ltd**  
SF No: 206, Kannampalayam (PO), Suler (Via)  
Coimbatore, Tamil Nadu 641 402  
☎ 0422 – 268 9855 • E-mail: info.india@eggerpumps.com



## Vibro Shifter

Sanjay Engineering Works offers machinery and equipments for chemicals, pharmaceuticals, pigments and dyes, agrochemicals, and fine chemicals. The Salient Features of Vibro Shifter: Suitable for widest range of material; Dust free arrangement, leads free sleeves; Easy dismantling and cleaning; Ideals for gradation and separation of dry powder granules and semi-solids/liquids; Less power consumption, variable flow pattern; Modes – ½", 20", 24", 30", 36", 40", 48"; Modular design of decks with easily fitted clamps; MOC: SS 304/316; Output 80 to 200 kg/hr depend upon characteristics of material; Noiseless; Maintenance free and high speed; Simple and compact construction.

Contact:

**Sanjay Engineering Works**  
Plot No: 5101/2 GIDC, Industrial Estate  
Ankleshwar, Gujarat 393 002  
☎ 02646 – 220 642 • Mob: 94278 74730  
E-mail: sanjayenggworks5101@gmail.com



## Hydraulic Bending Press

Hercules Roll Forming Machines offers an extensive range of Hydraulic Presses commonly referred as Press Brakes. A press brake is a machine used for bending sheet metal and metal plate, most commonly sheet metal. It forms predetermined bends by clamping the workpiece between a matching top tool and bottom die. Two C-frames from the sides of the press brakes are connected to a table at the bottom and on a movable beam at the top. The bottom tool is mounted on the table and with the top tool mounted on the upper beam. The offered products are fabricated by making optimum utilization of premium quality raw material and components that ensure durability and uninterrupted functions at the users' end. In order to cater the evolving demands of the clients the company has made these products available in different specifications. Parameters – Strip Width: Up to 4000 mm; Strip Thickness: 2 mm; Speed Up to 5 strokes/min; Mechanism: Hydraulic.



Contact:

**Hercules Roll Forming Machines**  
**Plant-I: C-113, Bulandshar Road, Indl Area**  
**Ghaziabad, Uttar Pradesh 201 002**  
**Mob: 99589 43311 / 981032 86042**  
**E-mail: rfm.hercules@gmail.com**

## Borewell Pump

Sanas Engineering Services offers Borewell Pump. The features are: a domestic borewell submersible pump or sub pump, electric submersible pump (ESP) is a device that has a hermetically sealed motor close-coupled to the pump body; the whole assembly is submerged in the water in a deep well ranging from 200 feet depth to 1200 feet to pump the water to the surface. The company, established in 2004, is a leading supplier of water supply pumps for a diverse range of applications across various industries. Their wide product range includes dewatering pumps, submersible dewatering pumps, dewatering equipments, dewatering pumps, diesel dewatering pumps, rainwater dewatering systems, sludge dewatering pumps, water pumps, booster pumps, and borewell pumps.



Contact:

**Sanas Engineering Services**  
**SR. No. 82/6B, Dangat Patil Nagar, Gurukrupa Complex**  
**Shivane Guru Krupa Industrial Estate**  
**Shivane, Pune, Maharashtra 411 023**  
**Mob: 98222 72229, 98222 62221**  
**E-mail: sanasengg@yahoo.com, sales@sanasengineering.co.in**

## Corn Flake Dryer Heater

Mark Engineers offers Heat Exchanger for Corn Flake Dryer Heater. Their features are: heat exchanger for corn flake dryer heater offered features use of SS process unit and comes with a single piece welded design with involved process contact parts made of SS-316, thus providing for contamination-free working; these systems also feature support of food-grade inflatable gasket manufactured using neoprene rubber or silicone rubber options that can accommodate variable sealing gaps; further, the system assists in delivering optimum heat transfer support through forced convection and is applicable in areas where the input is available in granular or crystal form; its features include: latest technology based dryer heaters for meeting the processing needs of corn flakes, featuring the use of SS process units with single piece welded design; all process contact parts made of SS-316 that provide contamination free working. Featuring support of food grade Inflatable Gasket manufactured using neoprene rubber/silicone rubber options that can accommodate variable sealing gaps; system delivers heat transfer through forced convection and is applicable in areas where input is available in granular/crystal form; the operation involves passing drying gas through the bed at desired velocity that promotes high heat transfer as well as quick drying rate; provides for uniformity in drying; brings reduction in drying time; comes with micro filter support for preventing any fine dust from passing through products with inlet air; and chamber and housing made from stainless steel grade SS 316; chamber provided with inspection window that comes duly sealed with toughened glass. The company is a manufacturer and exporter of heat exchangers, heaters for textile processing machines, tray dryers for chemical industries, dryers for pharmaceutical machinery, heat exchangers for food processing machinery, laminate heaters, dryers for salt industries, shell and tube heat exchangers, finned tubes, heating elements, oil coolers for earth moving machinery, oil coolers for hydraulic machinery, dryer heaters, and other industries.



Contact:

**Mark Engineers**  
**Plot No. I-312/2, Phase-2, H Road, G.I.D.C. Estate**  
**Vatva, Ahmedabad, Gujarat 382 445**  
**☎ 079 – 4008 3134, 2583 6558**  
**Mob: 98250 12504, 98250 30474**  
**E-mail: markheatcool@gmail.com**

**May 2024 : INTEC 2024 Exhibition + Focus:**  
**Machine Tools & Automobile Accessories**

## Submersible Sewage Pump

Jagdish Textile & Engg offers Submersible Sewage Pump. The features are: this range adopts a high-efficient 4P motor that has been tested by serious quality control and applied high-class insulation to provide long-term operation; a motor installed with an over-load protector to prevent the motor from overheating and overloading; the installation of a high-quality SIC seal to produce high wear resistance and leak-proof motors; speed of flow is superiorly designed and can be applied within large pump housings and impellers to achieve high efficiency and high performance for any wastewater; inner cable wires and cable base are upgraded by filling EPOXY to raise humidity resistance; drainage of the food market; wastewater treatment of animal husbandry, water refining tank waste water plant; drainage of the building basement, waste water treatment of the food industry; pulp and paper industry; steel mill; and other industries, etc. The company is a manufacturer, importer, and exporter of supreme grade high pressure pumps, car washer pumps, etc.



Contact:

**Jagdish Textile & Engg Co**  
**Ramoliya Bulding, Opp: Ashok Niwas, Kadia Kui**  
**Relief Road, Ahmedabad, Gujarat 380 001**  
**Mob: 98983 20500 • E-mail: info@jtecump.com**

## Precision Tubes

Hansa Tubes offers Precision Tubes. Their features are: They have 1 no's of high-speed tube mills with sizes ranging from ½' to 3' and an installed capacity of 24,000 MTPA; these are catering to the automobile and furniture industries. In the bicycle industry, they are supplying the world's No. 1 bicycle manufacturers, Hero Cycle and Avon Cycle; and these have an ultramodern plant at Derabassi. The requirement for raw material for C.R. precious tubes is being met by its narrow cold-rolled steel mill. The company was established in 1994. A simultaneous plant was set up in the industrial belt near Chandigarh at Dera Bassi in the state of Punjab with an in-house facility for cold-rolled steel strips and coils and high-frequency ERW precision tubes. Now it is an ISO: 9001 certified company and has 2 CR mills and 1 tube mill with a fully equipped workshop and testing lab to cater to the basic requirements of customers for end applications.

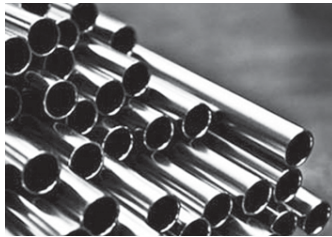

Contact:

**Hansa Tubes Pvt Ltd**  
**181/25, Indl Area-1, Chandigarh, Punjab 160 002**  
**Mob: 95925 00077 • E-mail: arjit.hansa@gmail.com**

## Electric Actuated Butterfly Valve

Trisha Engineers offers Electric Actuated Butterfly Valve. The features are: this plastic actuator body passes impaction and acid-base tests and also meets SGS. Valve position can be adjusted from 15 degrees to 90 degrees. The assembly of actuators and valves meets the EN ISO 5211 standard. Improved PP disc to enhance the performance. Thickened body and seal to extend the service life. Materials meet drinking water standards; the material has been modified by nanometers to improve the pressure resistance and impact resistance. Raw materials add anti ultraviolet absorbent and antioxidants, improving durability and aging resistance. The company is a leading supplier of quality sinking thermoplastic products, including PVC / PP / CPVC valves, pipes, and fittings. They cater to various industries like water treatment, metal finishing, chemicals, swimming pools, and spas.



Contact:

**Trisha Engineers**  
**#11, Sri Nivasam, Bull Temple A Cross, Behind Uma Theatre**  
**6th Main, Chamrajpet, Bengaluru, Karnataka 560 018**  
**☎ 080 – 2661 4315 • Mob: 93412 70830**  
**E-mail: trishaengineers@yahoo.com**

## Compact or Package Substation

Excel Power Switchgear Pvt Ltd offers Compact or Package Substation. Features are: packaged or compact substations are fully compartmentalized substations kept inside a prefabricated enclosure with MV switchgear, transformer, and LV switchgear; their compact substations are specially designed with the highest possible standards for personnel safety and a suitable ventilation system to suit local climatic conditions; and the enclosure of the CSS is manufactured using high-quality pre-galvanized sheet steel. This provides high resistance to corrosion, which is paramount in outdoor applications; its features include: transformers from 200 kVA to 3 MVA; extensible and non-extensible type MV switch gears up to 33 kV; LV ACB and MCCB feeder pillars and cabinets; automation and monitoring systems. The company, a high-tech manufacturing unit is engaged in R&D, production, and manufacturing of low and medium voltage switchgear.



Contact:

**Excel Power Switchgear Pvt Ltd**  
**15 First Street, Gandhi Nagar, Achugam Nagar**  
**Ekkatuthangal, Chennai 600 032**  
**☎ 044 – 2225 4870 • E-mail: sales@excelpower.co.in**

## Cooling Tower GCT Series

GEM Equipments (P) Ltd offers GCT Series Cooling Towers that are of high efficiency and designed by GEM engineers taking into account different environment and climate condition around the world, with reference CTI Standards. The Cooling Towers are manufactured with non-corrosive materials, which result in longer life with minimum maintenance. GCT Cooling Towers do not rot or rust like conventional towers since all main parts are made of high quality Fiberglass Reinforced Polyester (FRP) and rigid Poly-Vinyl Chloride (PVC). This eliminates the need for painting and repairs, reducing maintenance cost and guaranteeing long dependable service. The efficiency of the round, bottle-style GCT Cooling Tower is not only thermal, but operational, a fact that one should seriously take into consideration when choosing a cooling tower. Our 360 degree air intake and lower face velocity through the fill offers less air resistance, therefore requiring less motor horsepower than other cooling towers, and guaranteeing considerable electric energy savings. Typical Application: Air Compressor; Air Conditioning Plants, Aluminium Die Casting machinery; Diesel Generator; Furnace; Plastic machinery; and Process industries.



Contact:

**GEM Equipments (P) Ltd**

SF #103, Avinashi Rd, Arasur, Coimbatore, Tamil Nadu 641 407  
Mob: 93444 55297 • E-mail: sales@gemindia.com

## Pumps & Systems

Dharani Pumps manufactures a range of pumps such as Self-Priming pumps, Borewell Submersible pumps, Sewage and Sludge pumps, Swimming Pool pumps, Pressure Boosting pumps, Centrifugal pumps, Open well Submersible pumps, De-watering and Slurry pumps, etc.

Contact:

**Dharani Pumps & Motors**

S F No: 328, Kalapatti Road, Coimbatore, Tamil Nadu 641 048  
Mob: 95009 79630, 77080 69630 • E-mail: enquiry@peindia.net

## Hydraulic Products

Target offers a range of Hydraulic products like Hydraulic Piston Pump, Hydraulic Vane Pump, Hydraulic Orbital Motors, Hydraulic Radial Piston Motor, Hydraulic Solenoid Valves, Hydraulic Proportional Valves, Hydraulic Cylinders, Accumulators, Oil Coolers, Internal Gear Pumps, etc.

Contact:

**Target Hydrautech Pvt Ltd**

Building No: 6, Target House, Tulip Ind Complex  
Vasai-Naigaon Link Road, Bhoirpada, Vasai (East)  
Dist: Palghar, Maharashtra 401 208  
Mob: 80807 50080 • E-mail: sales@targethyd.com

## Variable Displacement Vane Pumps

Shuban Hydrotech offers Variable Vane Displacement-Pumps Produced by Berarma of Italy. Berarma has launched a new family of variable displacement vane pumps with high working pressure (250 bar). Model PHP pumps are high pressure variable displacement vane pumps equipped with hydraulic pressure regulating device that allow you to instantly adjust the flow rate accordingly to circuit requirements. Variable displacement vane pumps are volumetric type so they deliver a maximum flow rate equivalent to its displacement for their speed of rotation. Operating pressure is due to pressure loads encountered by the fluid within the system. When this value is achieved, pump reduces its flow rate to zero, keeping the pressure almost constant. In zero flow conditions, pump delivers oil only to compensate any possible drain and piloting. Features and benefits: Various pressure and flow rate controls; Maximum displacement limiter included; Arrangement for combined pumps available; High operating pressure; Excellent response times; Silent running; High efficiency; Long working life; Economy and simplification of hydraulic system; Modular design; and Energy saving. The company offers electrohydraulic solutions for high-end applications in the industrial hydraulics sector. It offers a complete range of products and solutions, including control valves, solenoid valves, proportional and servo valves, ATEX certified flame-proof valves, logic cartridge valves, poppet valves, cylinders and servo cylinders, etc.



Contact:

**Shuban Hydrotech**

#49, Gr Flr, 3rd X, 20<sup>th</sup> Dasarahalli Main Road, Sahakar Nagar  
Byatarayanapura, Bengaluru, Karnataka 560 092  
Mob: 99643 15671, 98440 31093  
E-mail: sales@shubanhdyrotech.com

## Chemicals

Prasol Chemicals Limited is among the leading forward integrated manufacturers of acetone derivatives and phosphorous derivatives in India. The products have end uses in four segments namely pharmaceuticals, agrochemicals, home and personal care and performance chemicals. The Company is a Government of India certified Two Star Export House Company with the global distribution network spread across 50 countries across Asia, North America and the European Union.

Contact:

**Prasol Chemicals Limited**

Prasol House, Plot No: A-17/2/3, TTC Industrial Area  
Khairne MIDC, Navi Mumbai 400 710  
☎ 022 – 6195 2500 • E-mail: inquiry@prasolchem.com

## Purge Set

Placka Instruments India offers Purge Set, which is a combination of a variable area flow meter and a regulator. Features: the purge set guarantees constant flow even under fluctuating pressure or load; use the purge set whenever you need constant feed of fluid; they make purge sets available in both panel mounting and panel-box type; it is a combination of a purge set, filter regulator, and inlet/outlet pressure gauge in one panel board; the necessary components for air purging are combined in one panel board that offers easy installation at site; stable purging flow is maintained even when the secondary (load) pressure varies; and they are manufactured completely according to the customers required specification. The company manufactures process control instruments such as air filter regulators, rotameters, level switches, level gauges, liquid level controllers, transmitters, etc.

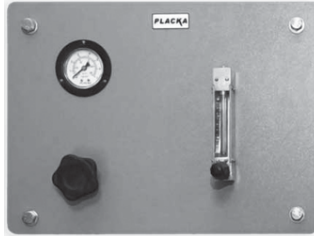

Contact:

**Placka Instruments India Pvt. Ltd**  
5 Ramamurthy Street, Nehru Nagar  
Chromepet, Chennai 600 044  
☎ 044 – 2223 1559, 2223 0187  
E-mail: [plackainstruments@yahoo.com](mailto:plackainstruments@yahoo.com), [placka@vsnl.com](mailto:placka@vsnl.com)

## Gear Oils

Sprint Lubricant offers Gear Oils. These EP type gear oils are recommended for hypoid, spiral, bevel, worm gears, transmission systems of cars, buses, LCV's, HCV's, etc.. Features: power transmission units of vehicles operating at low temperatures; steering gears; fluid-lubricated universal joints. Gear differentials, mechanical transmissions, and drive axles operate under severe duty conditions. Features include: long service life due to extremely good oxidation stability; excellent thermal stability; having anti-foam, anti-rust, and anti-wear properties; firm strength and good film formation; smooth gear operations; compatibility with other gear oils; heavy duty type possessing high load carrying capacity for sustained high speed and high torque service. The company is one of the upcoming brands that targets the satisfaction of customers by providing high-quality products; and believes in quality, so high-quality base stocks and additives are used in manufacturing.



Contact:

**Sprint Lubricant**  
47 Haribhakti Complex, Opp: M C High School  
Salatwada, Kareligh, Vadodara, Gujarat 390 001  
☎ 0265 – 2417 293 • Mob: 98252 26332  
E-mail: [info@sprintlubricant.com](mailto:info@sprintlubricant.com)

## Fluid Bed Dryer

Jay Pharma Equipments offers Fluid Bed Dryer. The features are: the fluid bed dryer is ideal for the rapid and even drying of chemical, pharmaceutical, and food products. Its features include: 65% open perforated air distribution plates along with dutch weave mesh; on-line sampling port: 2.5 kg to 500 kg batch capacity; top spray granulation; explosion relief disc; all contact parts are S.S. 316 as per GMP standard; uniform drying at low temperature; an intrinsically safe earthing system that ensures complete elimination of static charge; a fan motor unit and filtration unit that can be placed in remote areas; a top-mounted pneumatic cylinder (directly coupled) for shaking (without wire rope system); and pneumatically operated inflatable seals provided for filter bag and product container sealing with pressure switches and FRL to ensure fail-safe operation. The company was established in 2005; therefore, it is reckoned as the major manufacturer, exporter, and supplier of fluid bed dryers, octagonal blenders, inline homogenizers, etc.



Contact:

**Jay Pharma Equipments**  
B/309, Hospital Koldongri, Near Jeevan Vikas Kendra Marg  
Vile Parle East, Mumbai 400 057  
Mob: 91674 17838, 89760 79760  
E-mail: [jkpharm1@gmail.com](mailto:jkpharm1@gmail.com)

## Control & Relay Panel

Excel Power Switchgear offers Control and Relay Panel Model: CRP-11/33/66/132/230 kV. The Company is engaged in manufacture and supply of metering, control and protective relay panels, annunciator panels, and mimic control panels for transmission and distribution systems for industrial, utility, and powerstation applications up to system voltage 230 kV; its features include: best engineering design; sleek and excellent aesthetics of panels; simplex/duplex design; transparent glasses on front door for easy viewing; unitized construction; special profile gasket used for dust protection; suitable for top or bottom cable entry; reference standard IS 8623/IEC 61439; compatible with the IEC 61850 system. The company is engaged in R&D, production, and manufacturing of low and medium-voltage switchgear.



Contact:

**Excel Power Switchgear Pvt Ltd**  
15, 1st St, Gandhi Nagar, Achugam Nagar  
Ekkatuthangal, Chennai 600 032  
☎ 044 – 2225 4870 • E-mail: [sales@excelpower.co.in](mailto:sales@excelpower.co.in)



## Industrial Limpet Reactor

Sunrise Process Equipments offers Industrial Limpet Reactors. The features are: the Limpeted vessel with a closed rigid container is made using graded carbon steel and stainless steel alloy to ensure a fine finish and long-lasting usage; the vessel is equipped with a closed rigid container for effectively holding gases and liquids at different pressures; it is available in a sturdy construction that is easy to operate; based on these data, an analysis is conducted of the heat transfer requirements, degree of agitation, pressure-temperature ratings, space availability, surface finish requirements, product properties, hazop studies, corrosion allowance, etc., to offer an optimum system suiting the client's application. The company fabricates all kinds of equipments used in industries like pharmaceuticals, dyes, dye intermediates, polyester, effluent treatment, organic and inorganic production units, and all other chemical equipments.



Contact:

**Sunrise Process Equipments**  
102 A-Wing, Rameshwar Tower, Shimpoli Road  
Nr: Gokhale High School, Dalvi Nagar  
Borivali, Mumbai 400 092  
☎ 022 – 2899 3705 / 2899 3706  
E-mail: response@sunriseequipments.com

## Automatic Rotary Glass/ Pet Bottle Washing Machine

Veena Pharma Machinery offers Automatic Rotary Glass/Pet Bottle Washing Machine, which is a rotary bottle washing machine that is compact, highly efficient, and elegant in look; it has many functional features as per the GMP Standard to wash containers of glass, plastic, or other material. The bottles are loaded on a rotating platform where bottle holders, i.e., nylon cups, are specially designed to accommodate bottles with varying neck diameters and bottle diameters. The bottles are placed in an inverted position in the cups. The external cleaning of the bottles is done by spraying showers. Solenoid valves are provided to enable the regulation of the timing and sequence of various washing media to suit specific requirements. The company designs and delivers innovative and affordable packaging machines.



Contact:

**Veena Pharma Machinery**  
A-2/4, Padmini Industrial Complex, Kalher Pipe Line Road  
Nr: Gundvli Gaon, Purna Village, Bhiwandi  
Thane, Maharashtra 421 302  
Mob: 93239 58996, 90045 63628  
E-mail: sales@veenapharma.com

## Rotary Airlock Valve

Nutshell Engineers offers Rotary Airlock Valve. The features are: the prime function of a rotary airlock (rotary valves) is to regulate the flow from one chamber to another while maintaining a good airlock condition. The product is mainly in dry powder or granular form; in the dust filtration field, a good airlock is essential on cyclone and bag filter applications in order that the manufacturers quoted high dust collection efficiencies can be maintained. Airlocks are also important in the pneumatic conveying industry, where products are regulated into a pressure or vacuum conveying line while minimising air leakage. The company is a premium manufacturer, importer, trader, and exporter of flexible connections, relief valves, safety valves, explosion vents, rupture discs, flame arrestors, etc. Manufactured in accordance with industry-set norms and regulations, these products are known for their seamless finish, dimensional accuracy, longer functional life, easy installation, compact design, high strength, and durable construction.

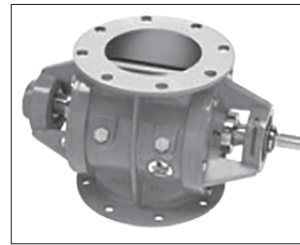

Contact:

**Nutshell Engineers**  
F-18, Basaveshwar Industrial Premises Vishweshwar Chowk  
Plot No. 2, Sector 10, Thergaon, Pune, Maharashtra 411 026  
Mob: 94220 17122, 77740 61105  
E-mail: info@nutshellengg.in, pavan@nutshellengg.in

## Non-Clog Submersible Pump

Kirloskar Brothers offers Non-Clog Submersible Pump. Speciality of this pump is: Dry/Wet Pit design; Motor-cooled by Ethylene Glycol Mixture; Mechanical Sealed Pump; Flood proof design for use in flooded condition (dry pit design); Available with LT/HT motor; Various safety features: Bearing temperature detector; Vibration sensors for bearings; Moisture sensors; Leakage sensor; Winding temperature sensor; Higher sustainable efficiency and corrosion resistant due to Corrocoat coating. Pump is suitable for working in Dry as well as Wet pit installation; Access to the equipment for inspection and service easier for personnel; No dependency on minimum submergence for motor cooling in wet pit design; Motor is cooled by Ethylene Glycol mixture.



Contact:

**Kirloskar Brothers Limited**  
Yamuna, Survey No: 98 (3.7), Baner  
Pune, Maharashtra 411 045  
☎ 020 – 2721 4444 • E-mail: marketing@kbl.co.in

## Chemical Storage, Reaction, Transport Tanks & Vessels

EPP Storage tanks are manufactured by the Contact moulding (hand layup) method or by filament winding (on CNC machines) method for the storage of Highly Corrosive Chemicals, Acids and Wastes. These tanks are offered as per customers' requirement complete with at all the relevant accessories. EPP offers storage tanks in various shapes and configurations like Square, Round, Rectangular, Vertical and Horizontal with flat bottom or conical bottom or dished end. Capacity: up to 500 kl. These cylindrical tanks can be suitable either for horizontal or vertical installations. The tanks are designed based on the application, capacity and installation requirements. They can also be supplied in dual laminate with thermoplastic lining. EPP also manufactures FRP and dual laminated Reaction Vessels, Pressure Vessels and Vacuum receivers for mixing, washing and filtration processes. Reaction vessels are offered with suitable lined agitator, gearbox and electric motor. Pressure vessels and vacuum receivers can be designed to suit the operating pressure up to 10 kg/cm<sup>2</sup> and for full vacuum services. MOC: FRP moulded and filament would use Isophthalic, Bisphenol, Vinylester and Epoxy Resin; PP and HDPE Spiral Wound; PP/FRP, PPH/FRP, PVC/FRP, CPVC/FRP, PVDF/FRP, ECTFE/FRP, FEP/FRP. Advantages: Good chemical and weather resistance – high physical and mechanical strength; Light in weight – easy to handle and install Good insulating qualities; Ease of maintenance with Zero Downtime.

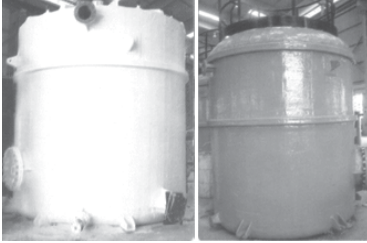

Contact:

**EPP Composites Pvt Ltd**  
Plot No: 2646, Kranti Gate Main Road  
GIDC Lodbhika Industrial Estate, Kalawad Road, Metoda  
Rajkot, Gujarat 360 021  
☎ 02827 – 287 059 • Mob: 70433 34762  
E-mail: bd@epp.co.in

## Valves, Pipes Fittings & Piping System

Dipflon Engineering & Co supplies a range of PTFE/PFA/FEP/PVDF/PP Lined valves and pipes fittings, which includes Ball check valves, SS ball valves, Lined ball valves, Diaphragm valves, Plug valves, Butterfly valves, Swing check valves; Spool pipes, Dip-pipes, Reducers, Equal cross, Red tee; Dis piece and spacers, expansion bellows, etc.



Contact:

**Dipflon Engineering & Co**  
B-413, BG Towers, Near Delhi Gate  
Shahibaug Road, Ahmedabad, Gujarat 380 004  
☎ 079 – 2562 4003, 2562 4169 • Mob: 099244 99948  
E-mail: info@dipflon.com

## Electro Hydraulic CNC Press Brake

GMT/Yangli presents HB Series Servo Electro Hydraulic Valve Hybrid CNC Press Brake coupled with Delem DA52S or DA66T intelligent controller it helps in accurate forming solutions. Hydraulic Crowning further enhances the accuracy by positive deflection compensation; Front Arms movable on linear guideways for operator convenience; Standard configuration is Y1, Y2, X, (+1) Axis can be supplied with other configurations. Various combinations of Die and Punch make this a must in any advanced Sheet Metal workshop that demands and provides accuracy. Specification of Model HB0412 – Nominal Force: 450 kN; Bending Length: 1250 mm; Frame Distance: 950 mm; Max Opening Height (E): 430 mm; Ram Stroke: 200 mm; Throat Gap (H): 370 mm; Worktable width (W): 50 mm; Approach Speed: 18 mm/s; Bending Speed: 18 mm/s; Return Speed: 200 mm/s; Back gauge Stroke: 500 mm; Machine Weight: 4500 kg; Machine Dimensions – 1680 mm (L) x 1980 mm (W) x 2470 mm (H).



Contact:

**GMT Engineers Pvt Ltd**  
H-7A, Krupa Colony, 1st Avenue  
Ashok Nagar, Chennai 600 083  
☎ 044 – 2371 1881 • Mob: 98409 11881 / 94446 78000  
E-mail: Prasad@gmtooffice.com

## Pharmaceutical Machines

Labsoul (India) offers a range of Pharmaceutical Machines like Capsule Filling machine, Tablet Making Machine and Tablet Section, Syrup Filling and Sealing, Ointment Filling and Sealing, Ayurvedic Pill Making machine, Homogenizers, Mixers, Ribbon Mixers, Sifter, Multi Mill, and Blenders. Labsoul is a renowned manufacturer, exporter and supplier of finest range of Laboratory Equipment.

Contact:

**Labsoul (India)**  
20-B, Tribune Colony, B/h: SD College  
Ambala Cantt, Haryana 133 001  
☎ 0171 – 400 0597 • Mob: 92159 92301, 90503 42622  
E-mail: labsoulindia@yahoo.co.in

## Thread Rolling Machines

Royal Machine Tools manufactures Automatic Thread Rolling Machine, High Speed Thread Rolling Machine and Trimming Machine, Cold Forge Header Machine, High Speed Cold Forge Pneumatic Clutch Header Machine, High Speed Vertical Thread Rolling with Automatic Feeder, etc.

Contact:

**Royal Machine Tools**  
263 St No: 5/4, Village Gill, Jasdev Singh Nagar  
Ludhiana, Punjab 141 003  
Mob: 96977 78000 • E-mail: royalmachinetools48@gmail.com

## V-Notch Ball Control Valves (Series 300)

Pneucan Valves Pvt Ltd offers V-Notch Ball Control Valves (Series 300). Technical Specifications – Design: Complies to BS: 5351; Valve Size: 15 to 300 mm (1/2" to 12"); Body Type: V-Notch/Full bore conventional; Rating: 150 ANSI; Flow Chart: Equal %/On-Off; Material – Body: Carbon Steel, Stainless Steel, etc.; Ball: Stainless Steel; Seal: Teflon, Viton; Temperature: 180°C with PTFE Seal; 250°C with Viton Seal; Actuator: Diaphragm, Rotary or Electrical. Design and Performance Features: Full bore straight through construction turbulence free flow with wide rangeability; High Cv to body size ratio; Tight shut of leakage Class VI; Suitable for control action with carefully contoured V-notch resulting in a nearly equal % characteristic; Ball machined to fine finish hard-chrome plated and mirror polished to increase ball seal life; Preventing dust and dirt out of the working mechanism; Reliable operation and ideal for abrasive slurries or solids. The Company's products range includes: Diaphragm Control Valves (Series 400); Globe 3-Way Control Valves (Series 130); Butterfly Control Valves, Globe 2-way Control Valves (Series 110), Flush Bottom Valves (Series 500); Pressure Regulating Valves, Desuper Heater (Series 800), Power Cylinders, etc.



Contact:

**Pneucan Valves Pvt Ltd**  
Plot No: A-35, Road No: 10, Wagle Estate, Thane 400 604  
☎ 022 – 2583 8371, 2583 8372  
E-mail: info@pneucanvalves.com

## NOP Filter Pump

Nippon Oil Pump India Private Limited offers NOP Filter Pumps. Various components of the coolant unit are all combined in one. Filter pump is patented technology from NOP Japan whereby Machine Tool Users can reduce the footprint of the coolant system and energy consumption and improve the machine uptime and utilization. FILTER Pumps are media-free (no paper for filtration) and hence environmentally friendly. Motor: 2200-3700 W; Flow Rate: 12~28.8 lit. /min; Maximum Pressure: 7.0 MPa. The Company offers High Pressure and Medium Pressure Filter Pumps, Cyclone Filter Pumps, etc.



Contact:

**Nippon Oil Pump India Private Limited**  
Building No: 3, Plot No: 175-176, 11<sup>th</sup> Main, 3<sup>rd</sup> Phase  
Industrial Area, Peenya, Bengaluru (Urban)  
Karnataka 560 058  
☎ 080 – 4123 8431 • E-mail: info@nopindia.com

## Angle Valves

Sude Engineering Corporation offers Angle Valves and other allied products for all Process/Pharma/Food Grade and other related industries. Typical Constructional view of Angle Valve: Easy to install – infinitely rotatable actuator allows pneumatics connection in any position; 50% more economical than ball valves; 600% longer service life than ball valves; Compact design; Fast Response; Water hammer free. The Company's products range includes: Solenoid valves, Pneumatically operated Control Valves, Motorised Valves, Pneumatic and Electric Operated Ball/Butterfly valves; Pneumatic and Motorised Dampers; Pneumatic and Motorised VIV Dampers; Motorised Rising and Non-rising Sluice valve; Heavy duty – single phase and three phase actuators for operating Gates and Chutes; Pneumatic and Motorised Pinch Valve; Pneumatic and Motorised Flush Bottom Valve; Entire range of Electrical Actuator; and Instrumentation products.



Contact:

**Sude Engineering Corporation**  
1106 10<sup>th</sup> Main Road, RPC Layout, Nr: RPC Layout Bus Stand  
Hampinagar, Bengaluru, Kanataka 560 104  
☎ 080 – 2330 2145, 2314 1104 • Mob: 98450 18216  
E-mail: sudeengg@gmail.com

## Multistage Pumps

Sharp Pumps Pvt Ltd supplies Multistage Pumps. This vertical Multistage Inline pump can be used for a wide range of application. These pumps are also available in various combinations of materials. The maximum operating pressure of these pumps is up to 30 kg/cm<sup>2</sup> and the flow range is from 1 m<sup>3</sup> to 85 m<sup>3</sup>. A wide range of seals are available for different applications. These pumps are foot mounted and meant for: Pressure Boosting system; Hydro pneumatic system; High Pressure Cleaning systems; Saline Water applications; Ultra Filtration Systems; Reverse Osmosis System; and Fire Fighting. Technical Data – Voltage and Phase: 230 V – 1 phase, 515 V – 3 phase; Insulation Class: F; Protection Class: IP68; Speed: 2880 RPM; Frequency: 50 Hz; Casing: FG 200, CF 8; Impeller: SS 304, SS 316.



Contact:

**Sharp Pumps Pvt Ltd**  
Point Arcade, Sharp Nagar, Kalappatti  
Coimbatore, Tamil Nadu 641 048  
Mob: 90477 77757, 97861 97100  
E-mail: info@pointpumps.com

## Kitz Butterfly Valves

Zenith Trading Co offers Kitz Butterfly Valves. The features are: in order to fulfill the ever changing demands of their clients, they have been engaged in offering a quality range of kitz butterfly valves; these valves are widely appreciated for their durability, resistance against rust, and smooth working; the products are developed under the supervision of experts, employing the latest technological machines and tools. Moreover, these valves are tested on various parameters before the final delivery in order to offer a tested range to their clients; their features include: handles for extreme pressure; efficient design; dimensional accuracy; a fine finish and workout; a rigid and sturdy design; negligible pressure loss; and everlasting superior performance. The company is one of the most well known dealers, manufacturers, wholesalers, traders, and retailers of kitz valves, water meters, industrial valves, metal valves, electromagnetic flow meters, and much more.



Contact:

**Zenith Trading Co**

29/61 Sembudoss St, Parrys, George Town, Chennai 600 001

☎ 044 – 3295 7270, 2522 9760

Mob: 98411 30142 • E-mail: kaizardhaman@vsnl.net

## Clear Water Pumps

Darling Pumps Pvt Ltd offers Clear Water Pumps. The features are: these darling openwell submersible pumps are not only unique in design but are also very compact, sturdy, and highly reliable. Offered pumps up to 120 HP and head range up to 140 mtrs.; these pumps come with mechanical seal and ball bearing designs and thus can be installed in inclined positions as well; these pumps can be customized for oil-filled motors or air-filled motors as well; their applications include: this range of darling open well submersible clear water pumps consists of S and M series pumps. These pumps are not only ideal for various agricultural applications but are also very popular for many industrial applications as well. The company, with its expertise spanning over 35 years, has been the chief architect of the submersible pump revolution in India. With every new and innovative product line, it has set a benchmark for others to follow and has thus always kept one step ahead of the market.



Contact:

**Darling Pumps Pvt Ltd**

340/2 Tigaria Badshah, Nr: Agarbatti Complex

Sanwer Road Indl Estate, Indore, Madhya Pradesh 452 015

Mob: 99819 92833 • E-mail: dpplin@darlingpumps.in

## Vertical Turbine Pumps - SVT

Sintech Precision Products Limited offers Vertical Turbine Pumps – SVT. The features are: this range of vertical pumps offers the widest range of selection depending upon the pumping liquid, from clear water to varying degrees of contamination; these pumps are designed to operate at 50 Hz or 60 Hz in a single or more than one stage according to the head required; vertical pumps take little space in plan since the liquid is led away to the axis of the shaft; due to the positive head at suction, the pump gives its rated performance as well as high overall efficiency, whereas in horizontal pumps, due to losses in the suction line, foot valve, etc., the rated performance of the pumps is not achieved. The company, established in 1986, is one of the leading pump manufacturing companies in India.

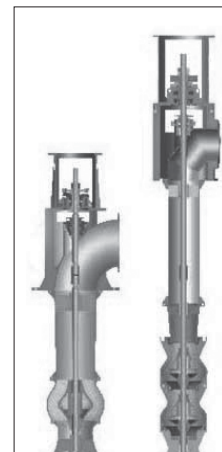

Contact:

**Sintech Precision Products Limited**

C189-190 BS Road Industrial Area

Ghaziabad, Uttar Pradesh 201 002

☎ 0120 – 417 6000 • E-mail: sales@sintechpumps.com

## Twin Screw Pumps

UT Pumps & Systems offers Twin Screw Pumps. The features are: these twin screw pumps are self-priming, double ended positive displacement pumps with external timing gears and bearings; their design provides complete axial balancing of the rotating elements and eliminates all metal-to-metal contact within the pump, making them suitable for dry running; their features and advantages are: separate screw and shaft assembly; combination of material possible for screw and shafts; independent material of construction for screw and shaft, respectively; replacement needed for damaged parts only; change in performance characteristics possible by changing screws only; change in pump design possible from long shaft to small shaft; and vice versa. The company was established as a joint venture partner with a leading German manufacturer of screw pumps, J H Bornemann in 1984 under the name and style Bornemann India Limited. It has been manufacturing its range of screw pumps in terms of its technology transfer agreement with the German company.



Contact:

**UT Pumps & Systems Private Limited**

14/7 Mathura Road, Faridabad, Haryana 121 003

☎ 0129 – 404 5831, 404 6882, 227 4861

E-mail: sales@utpsl.in

## Ball Valve, 3-Piece Flanged End

Rasaii Flow Lines offers Ball Valve, 3-Piece Flanged End. Features: Full bore and reduced bore (CI/DI/WCB/CF8/CF8M/CN7M/CF3/CF3M/Hastelloy B&C/CZ100). Design

Standard: BS 5351/EN ISO 17292/ASME B16.34; Pressure Class 125, 150 and 300; Size: 15 mm to 150 mm – 3-piece design; Body: ASTM A 351 Gr CF8/CF8M; Trim: AISI 304/304L/316/316L; Seat: PTFE/Peek; Rating: ASME Class 150/300; Face to Face: ASME B16.10; End: ASME B16.5; Testing Std.: BS 6755-1/API 598; Optional: Fire Safe – API 607; Mounting Pad – ISO 5211. User areas: Refineries, Petrochemical, Fertilizers, Sugar, Paper industry, Steel, Cement, Pharma, Waste Water, Food, and Power Plants, etc.



Contact:

**Rasaii Flow Lines Pvt Ltd**  
Ferndale, 1<sup>st</sup> Avenue, RWD Palm Layout  
Nr: Gayathri Nagar, Medavakkam, Chennai 600 100  
Mob: 93848 00896 / 93848 00897  
E-mail: admin@rflvalves.com

## Stainless Steel

Shalco Industries offers Stainless Steel. Their features are: stainless steel re-discovered in the early 19th century, is an alloy of iron with the main characteristic of corrosion resistance; this alloy is corrosion resistant due to the presence of a minimum 10.5% chromium, which forms a passive oxide layer on the surface of the steel naturally by combining chromium and oxygen in the air, protecting the steel from getting rusted; higher the level of chromium, the greater the alloy's resistance to corrosion. If the surface of the metal gets scratched, it quickly reforms; the grade and type of stainless steel must be chosen on the basis of corrosion resistance requirements suitable for a specific environment; they use stainless steel for a wide range of products like seamless and welded pipes, sheets, plates, wires, fittings, bars, flanges, etc. The company is an ISO 9001:2008 certified company and a leading manufacturer of steel and stainless steel products. Having its parent establishment in the year 2000, Shah Hastimal Laxmichand & Co. is today among the leading steel brands not just in India but also internationally. Some of the products manufactured by Shalco Industries are ferritic, austenitic, and duplex stainless steel, nickel alloys, and copper nickel.



Contact:

**Shalco Industries Pvt Ltd**  
56 Second Floor, Office 24, Kika Street, Marine Lines East  
Jamli Mohalla, Gulal Wadi, Bhuleshwar, Mumbai 400 004  
☎ 022 – 6249 8200, 6249 8214  
E-mail: info@shalco.in, ramesh@shalco.in

## Ceramics for Pump Industry

CUMI offers high performance material solutions that have proven successful in a wide range of applications in Pump industry. Some of the application includes: Pump shaft sleeves; Pump plungers; Pump Cylinder liners; Shat and Bush bearings; Piston for metering and dosing pump. The Ceramics finds it application in wide variety of pumps like Slurry pumps, Centrifugal pumps, Seall-ess – Magnetic driven pumps, Canned Motor pumps, etc.



Contact:

**Carborundum Universal Limited**  
**Industrial Ceramics Div, #47, 48 (Part) Sipcot Indl Complex**  
**Hosur, Tamil Nadu 635 126**  
☎ 04344 – 304 700, 304 713  
E-mail: enquiryic@cumi.murugappa.com

## Swimming Pool Heat Pumps

Suntec Energy Systems supplies Swimming Pool Heat Pumps, which are designed to heat Swimming Pool, Residential Pool, Spa, Jacuzzi, etc. Water temperature can reach as per requirements up to 45°C; same has much more efficiency than that of Gas or Electrical heater; wide range of capacities from 3 kW to 200 kW in different models. Salient features: 80% electrical saving; Water outlet temperature 45°C (max); Environment friendly refrigerant; High efficient Compressor; High efficiency Titanium Heat Exchanger; Easy control through smart controller; Unique air heat exchanger for high efficiency; Intelligent defrosting; Centralized controlled possible' Easy to install and operate.



Contact:

**Suntec Energy Systems**  
Plot No: 56, GIDC Estate, Phase-1, Naroda  
Ahmedabad, Gujarat 382 330  
☎ 079 – 2280 5529 / 2280 5530  
E-mail: marketing@suntecenergy.in

## Membrane Filter Holder

Champion Filters offers Membrane Filter Holder (MFH), which is manufactured from SS 316L quality provided with non-stick SS perforated sieve and wire support screen at center, inlet and outlet connections, air valve. Pharmaceutical grade silicon O-ring provided for air-tight sealing. Plates are tightened with wing nut.

Contact:

**Champion Filters & Process Equipments**  
8 Riddhi Siddhi Sagar Premises, Siddhi Sagar, Chinch Pada,  
Vasai (E), Dist: Palghar, Maharashtra 401 209  
Mob: 98923 78365 / 86523 2705  
E-mail: championfiltersprocess@gmail.com

## Welded Tubes Pipes

Heavy Metal And Tubes Ltd offers Stainless Steel Welded Tubes Pipes. The features are: these stainless steel welded tubes/pipes are produced out of prime quality stainless steel strips procured from reputed approved vendors; strips are converted into tubular form over a continuous tube mill; edges are welded using the tungsten inert gas (TIG) welding technique; inside weld bead is removed with bead scarfing equipment fitted on the mill; welded tubes/pipes are subjected to solution annealing, straightening, and pickling operations; and finished tubes and pipes undergo various testing as per the specification/customer's requirements, followed by marking and packing. The company has three separate workshops: one for producing stainless steel tubes and pipes, the second for producing carbon, and the third for hot-finished carbon and alloy steel tubes and pipes. All the units are fully equipped with state-of-the-art manufacturing facilities and the latest testing facilities. All the workshops are approved by leading national as well as international inspection agencies, consultants, EPC contractors, refineries, process plants, and major corporations.

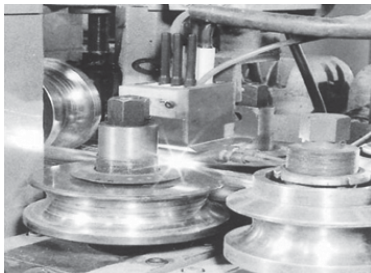

Contact:

**Heavy Metal and Tubes Ltd**  
201-Ashwarath Complex, Opp: Hotel Fortune Landmark  
Ashram Road, Ahmedabad, Gujarat 380 013  
☎ 079 – 2755 3243  
E-mail: [info@heavytubes.com](mailto:info@heavytubes.com)

## High Pressure Hydrotesting Pumps

Hydraulic Machines And Spares manufactures high pressure hydro testing pumps, for industrial applications. Flow rate of the pumps from 10 liters/min to 1000 litres /min; Pressure rating from 50 bars to 1000 bar; Pumps are mounted on the skid, it is motorized driven or engine driven. Applications are: Aerospace – Landing gears and wing flap; Automotive – Earth Moving Equipment; Agriculture – Tractors; Civil works – Excavators, Bulldozers, and attachments; Oil and gas industries; Power Generation – Flow controls for the water gates; Motorway repairs and maintenance.



Contact:

**Hydraulic Machines And Spares**  
302 Jay Ganesh CHS Ltd, Bamanpuri Road, J B Nagar,  
Andheri (E), Mumbai 400 059  
Mob: 93210 20713 / 81047 68901  
E-mail: [hydraulicmachinesandspares.com](mailto:hydraulicmachinesandspares.com)

## Air Filter-cum-Pressure Regulator

Your Air-Actuated Instrument and Equipment work at their best for a long period when you feed with clean dry air at a constant prescribed pressure. PLACKA FPR-Series Air filter-cum-Pressure Regulator removes completely the moisture and dust particles, and provides the exact pressure constantly at varying air demands. Its compactness and highly accurate performance for a long period with minimum of maintenance make for an optimum compromise between the ideal and the practical, consistent with end-use. This economically priced unit is extensively used for Process Control Instruments, Air-actuated Control Valves, Cylinders and other equipments. Salient Features: Longer life assured as the materials used are selected for their corrosion resistance and long wear; Excellent characteristics throughout the full flow range particularly at low flow zone in which the unit usually serves instruments; Negligible pressure drop due to high porosity ratio of the filter. The filter is reusable and has a high impact strength; In addition to solid particles, the unit extracts a high percentage of water thus, ensuring trouble-free service even in the most adverse conditions; Built-in relief ensures rapid response to circuit-induced pressure changes; The dust and liquid contaminants can be fully drained out when the Regulator is mounted both vertically and horizontally as in the case of Control Valves, Transmitters, etc; Custom made Unit for Control Valves, Transmitters and other field mounted Instruments; Regulator adjustment knob is easily lockable by the finger operated locking nut; Simple, versatile built in mounting arrangements by bolts and clamps. For panel mounting, tapped holes are provided at the top of the spring case for mounting screws; Model FPR-S with SS components instead of brass, for corrosive working conditions of fertilizers, refinery and steel plants.



Contact:

**Placka Instruments India Pvt Ltd**  
#5, Ramamoorthy Street  
Nehru Nagar, Chrompet, Chennai 600 044  
☎ 044 - 2223 1559 • E-mail: [sales@plackainstruments.com](mailto:sales@plackainstruments.com)

## Zinc Sulphate

Empeef Chemicals supplies Zinc Sulphate  $ZnSO_4 \cdot 7H_2O$ . Uses: Precipitating Agent for Viscose, Animal Feeds Fertilizer, Zinc Galvanizing, etc.

Contact:

**Empeef Chemicals Pvt Ltd**  
Plot No: T-114, MIDC Tarapur, Boisar (W Rly)  
Dist: Palghar, Maharashtra 401 506  
☎ 022 – 2893 4619 • E-mail: [costpr@mtnl.net.in](mailto:costpr@mtnl.net.in)

## Two-Stage Gas Burners Class III with Built-in Inverter

Nirmal Energy Limited, an ISO 9001: 2015 certified company, introduces to the Indian market new two-stage gas burners in Class III with built-in inverter manufactured by Baltur SpA of Italy. With years of experience and compliance with increasingly strict regulations regarding reduction of emissions and energy consumption, Baltur has continued on the

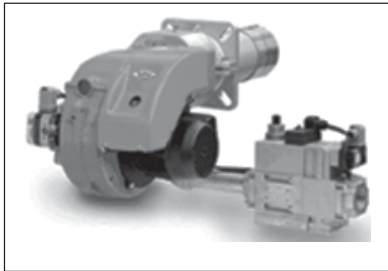

path of innovation for which it stands out, redesigning and repositioning on the market a number of burner lines allowing it to acquire an important new share of the market. The latest in this series of research and development (R&D), the company evolved with new two-stage gas burners with built-in inverters. It is significant that the inverter uses a true Drive Control developed and patented by Baltur for two-stage and modulating burner motors. Burners conforming to: Gas directive 90/396/CEE; EMC Directive 89/336/CEE; LV Directive 73/23/CEE; and Reference Standard: EN676. Product benefits: Major energy savings; Easy use and start-up; Excellent price to performance ratio; and one of its kind in the monoblock pressure jet burners.

Contact:

**Nirmal Energy Limited**  
C/U/14-16 Swatang Complex, Jodhpur Village Road  
Satellite, Ahmedabad, Gujarat 380 015  
☎ 079 – 2692 3170 • Fax: 079 – 2692 3469  
E-mail: info@nirmalenergy.com

## Flame Retardant & Smoke Suppressant Chemicals FAM-501

Niknam Chemicals (P) Ltd supplies FAM-501, a one pack Flame Retardant and Smoke Suppressant developed for Plasticized PVC applications. It is an Aluminium and Magnesium inorganic complex synergist treated with dispersing aids, which results in the superior dispersion, process ability and compatibility of FAM-501 with the polymer hence imparting superior flame retardant and smoke suppressant properties as compared to the other traditional synergists especially in PVC. Synergism of FAM-501 has also been reported along with high dosage of ATH in FRLS PVC Formulations. Typical Specifications – Properties – Appearance: White Powder; Moisture: 0.20% (max); Bulk density: 0.40-0.45 g/cc; Average particle size: 1-1.5 microns; Sieve residue (at 325 mesh): 0.01% (max).

Contact:

**Niknam Chemicals**  
311 III Floor, J Block Community Center, Ansal Classic Tower  
Rajouri Garden, New Delhi 110 027  
☎ 011 – 2510 311 • Mob: 98111 22226  
E-mail: niknamchemicals@vsnl.com

## Submersible Portable Pumps, PST Series

MBH Pumps (Gujarat) offers PST Series Submersible Portable Pumps, also known as cutter pumps, these pumps are fully foldable, vertical, closed coupled single stage submersible motor pumps.

These pumps are your solution for critical application. Technical Specifications – Head: 32 metres; Capacity: 170 m<sup>3</sup>/hr; HP: 0.5 to 10; RPM: 2900/3550; MOC: Cast Iron, Aluminium, Stainless Steel; Frequency: 50/60 Hz. Uses: Automatic dewatering of Pits; Yards and basements subjected to flood risk; Portable applications. The Company's products range includes: Centrifugal Self Priming Pumps, H<sub>2</sub>O Series Centrifugal End Suction Pumps, Ni-HARD Series Submersible Slurry Pumps, DC Series Submersible Dewatering Pumps; Monoblock Pumps, etc.



Contact:

**MBH Pumps (Gujarat) Pvt Ltd**  
Plot No: 14, GIDC Indl Estyate, Naroda  
Ahmedabad, Gujarat 382 330  
☎ 079 – 2282 3066, 2282 1018  
E-mail: marketing@mbhpumps.com

## Welded Type Cylinders

Fluidics Engineers Pvt Ltd offers Welded Type Cylinders. They are rugged and reliable cylinders due to their welded design and threaded cap.

This type of cylinders are usually had a narrow body and often a shorter overall length and can be offered with long strokes. Specifications – Rated Pressure: 210 kg/cm<sup>2</sup>; Cylinder Bore Diameter up to 400 mm; Strokes up to 5000 mm; Temperature range: -20°C to 90°C (Optional sealing systems for temperatures up to 180°C).



Contact:

**Fluidics Engineers Pvt. Ltd**  
468 Ponnaiyan Street, Crosscut Road, Gandhipuram  
Coimbatore, Tamil Nadu 641 012  
Telefax: 0422 – 223 6914, 223 2920  
E-mail: fluidics@fluidsmith.com

To view our e-magazine  
visit: [www.ips.co.in](http://www.ips.co.in)

## Soft Seated 2-Piece Ball Valve

Micro Pneumatics offers 2 Piece designed soft seated ball valve, which is manufactured as per BS EN ISO 17292, API 6D; Pressure Testing API 6D, API 598, BS 6755; Fire Test API 6FA, BS 6755 Part II. Designs – Floating Ball valve and Trunnions Mounted Ball valve. Floating Design – Independent Ball and Stem to minimize the effect of the side thrust generated by the pressure acting on the Ball. Two independent Floating Seat Rings assure Bi-directional zero leakage at maximum rated pressure. Trunnions Mounted Ball Design – The Ball is fixed and the seat Rings are floating free to move along the Valve Axis. At low pressure the Set Sealing action is achieved by the thrust of the spring's actions on the Seal Rings. As the pressure increases the seat rings are pushed against the Ball. Mounting Interface: ISO 5211; MOC of the Body WCB, CF8, CF8M, CF3, CF3M (Special on request); Trim – CF8, CF8M, CF3, CF3M (Special on request) Seat – PTFE, RPTFE (Special on request); and Size: ½" to 16".



Contact:

**Micro Pneumatics Pvt Ltd**

Plot No: 133-134, Vasai Municipal Indl Area, Umela Phata, Papy, Vasai Road (West), Dist: Palghar, Maharashtra 401 207  
☎ 0250 – 232 0458 • Mob: 83089 59200 / 85558 00888  
E-mail: micropneumatics@vsnl.net

## Laboratory Instruments, Hospital Furniture & Glassware

Kay Pee Udyog, an ISO 9001: 2015 Certified Co, manufacturers and Exporters of Laboratory Instruments, Hospital Furniture and Glassware. Their products range includes: Research Equipments, Lab Equipment, Pharmacy Instruments, Autoclaves, ETO and Sterilizers, Blood Band Equipment, Lab Glassware, Microscopes, Analytical Instruments, etc.

Contact:

**Kay Pee Udyog**

# 101, HSIIDC Industrial Estate  
Ambala Cantt, Haryana 133 006  
Mob: 98961 24839, 98964 32272  
E-mail: inquiry.kaypeeudyog@gmail.com

## Tubings & Fittings

Duncan Engineering Limited offers Maxflow range of Tubings & Fittings. Features: Quick assembly and dismantling; Standard sizes: 4, 6, 8, 10 and 12 mm; and huge range.

Contact:

**Duncan Engineering Limited**

F-33, MIDC, Ranjangaon, Karegaon, Tal: Shirur, Pune, Maharashtra 412 209  
☎ 02138 – 660 066 • E-mail: pbu@duncanengg.com

## Ceramics for Fluid Handling Applications

Carborundum Universal Limited, Industrial Ceramics Division offers Ceramics for Fluid Handling applications. In the transport of aggressive fluids, ceramic components provide exceptional resistance to corrosion, mechanical version and abrasion while maintaining their superior surface finish and fit. Materials offered: High Alumina (95%, 99.5%, and 99.8% purity); Reaction Bonded Silicon Carbide; Yttria Partially stabilized Zirconia; and Sintered Silicon Carbide.



Contact:

**Carborundum Universal Limited**

**Industrial Ceramics Division, # 47, 48 (Part)**  
**SIPCOT Industrial Complex, Hosur, Tamil Nadu 635 109**  
☎ 04344 – 304700 / 304713  
E-mail: customercareic@cumi.murugappa.com

## Syrup Manufacturing Plant

KPM Pharma Machineries, manufacturers of Pharmaceutical and Chemical Machinery offers Syrup Manufacturing Plant. Features: Extremely hygienic processing; Least manual handling; Design compliance with cGMP; Capac-

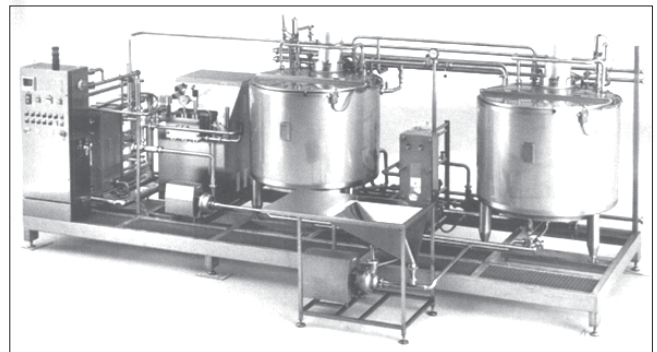

ity up to 10,000 litre; Product Contact AISI 316L; Atmospheric, Vacuum or Pressure operation; Jacket for heating and cooling; Vessel Inside Pressure; Heating Jacket Pressure; Heating by steam or hot water circulation; Thermal Insulated; Mechanicals or Electro polishing of internal surface; Welded, flanged or hinged type over; Integrated Cleaning in Place-CIP; Sterilizing in Place-SIP as an option; Portable execution on request. The Company's products range includes: Fluid Bed Dryer, Rapid Mixer Granulator, Octagonal Blender, Double Cone Blender, Multi Mill, Cone Mill, Vibro Sifter, Tray Dryer, Roll Compactor, Mass Mixer, Ribbon Blender, Starch Paste Kettle, Roll Compactor, Colloidal Mill, Inline Homogenizer, Zero Hold up Filter Press, etc.

Contact:

**KPM Pharma Machineries**

Unit No: 212, 2<sup>nd</sup> Floor, Centre Pointe, Sativali Road  
Valiv Phata, Vasai East, Dist: Palghar, Maharashtra 401 208  
Mob: 98333 44890 / 80077 14455  
E-mail: kotharikpm1@gmail.com



## Gate Valves

Mawa Engineering Works manufactures Gate Valves. Its design and mfg: API 600, API 6D, BS 1414; Pressure Rating: Class 150 to 2500; Pressure and temperature ratings:

ASME B16, 34; Size: 50 mm to 400 mm; End Connection: ASME B16.5; Face to face dim: ASME B16.10; Inspection and Testing: API 598; Operation: Hand wheel, Gear operated, Electrical; Material of Construction: WCB, CF8, CF8M, CF3M, CN7M, Hastelloy C and all alloys; Special: Pressure seal bonnet and bellows seal gate valves. The Company's products range includes: Butterfly valves, Globe valves, Swing Check valves, Ball valves, Dual Plate check valves, Plug valves, Wafer check valves, Double Block and Bleed valve, Control valve, Torque Tester (electronics), Pipes and Fittings, Strainer Y Type, Conical Strainer, etc.



Contact:

**Mawa Engineering Works**  
5-6 Darbar Manzil, B/h: Jai Hind Hotel, Sarkhej,  
Ahmedabad, Gujarat 382 210  
Mob: 93270 13245 • E-mail: mawaenggworks@gmail.com

## Clean Room High Speed Doors

Gandhi Automations Pvt Ltd offers Prime Clean Reset Air Tight Self-Repairing Clean Room High Speed Doors, which are designed for internal applications and protects your internal environment against draughts, humidity, dust and dirt. Features: Its operating speed and superior sealing properties improve traffic flow and provide the required environmental control thus saving on energy costs. The doors operate on the concept of low air permeability in pressurized rooms with positive and negative air pressure. High door efficiency and low permeability values range as EN 12426 EN 12427: < 12 m<sup>3</sup>/m<sup>2</sup>h 50 PA. High leak tightness is due to curtain being tightly integrated in special finish side guides. Bottom safety edges and inbuilt photo cells combine to ensure operator safety at all times. Heavy duty motor: 230 V three phase, opening speed up to 2.0 m/s with inverter system. Size up to: 4000 mm (W) x 4000 mm (H).



Contact:

**Gandhi Automations Pvt Ltd**  
Chawda Commercial Centre,  
Link Road, Malad (West), Mumbai 400 064  
☎ 022 – 6672 0200 / 6672 0300 • E-mail: sales@geapl.co.in

### Subscription Order Form

To,  
The Circulation Manager  
**Product News Publication**  
104, Sudama Yash, Nr. Ramkrishna Hotel  
Kelkar Cross Road, Ram Nagar, Dombivli (E), Thane 421 201

Dear Sir,

I / We would like to subscribe **Industrial Products Source**.

Please commence my/our subscription with the \_\_\_\_\_ (Month & Year) Issue.

Name \_\_\_\_\_

Address \_\_\_\_\_

\_\_\_\_\_

\_\_\_\_\_ Pin code \_\_\_\_\_

Telephone \_\_\_\_\_ Mobile No. \_\_\_\_\_

Date: \_\_\_\_\_ Signature \_\_\_\_\_

## Industrial Products Source

Visit us at: [www.ips.co.in](http://www.ips.co.in) / [www.industrialproductssource.com](http://www.industrialproductssource.com)

1-Year (12 issues) ₹ 300/-

2-Year (24 issues) ₹ 550/-

3-Year (36 issues) ₹ 750/-

*Subscribers who wish to receive magazine through courier, will be charged extra*

I / We enclose the payment of Rs. \_\_\_\_\_

in favour of **PRODUCT NEWS PUBLICATION**,

by "A/c. Payee" Draft / Cheque No. \_\_\_\_\_

Dated \_\_\_\_\_ of Bank \_\_\_\_\_

\_\_\_\_\_

Our Bank details for NEFT payment Transfer:

Name of the company: **PRODUCT NEWS PUBLICATION**

Name of our bankers: IDBI BANK, Dombivli (East Branch)  
Thane Dt.

A/C NO: 118102 00000 6569

Nature of Account: Current

IFS Code: IBKL0000455

## Hydraulic Presses

Hydraulic Machines And Spares offers Hydraulic presses, which are commonly used for assembly and disassembly of tightly-fitting components. In manufacturing, they are used for forging, clinching, molding, blanking, punch-

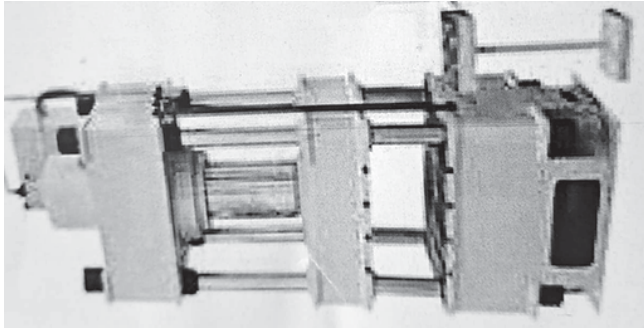

ing, deep drawing, and metal forming operations. Hydraulic Presses are also used for stretch forming, rubber pad forming, and powder compacting. The Hydraulic Presses' advantageous in manufacturing is, it gives the ability to create more intricate shapes and can be economical with materials. A Hydraulic Press will take up less space compared to a mechanical press of the same capability. The Company also manufactures Hydraulic Cylinders. Its applications are as below: Aerospace: Landing gears and wing flaps; Automotive: Earth Moving Equipment; Agriculture: Tractors; Civil works: Excavators, Bulldozers, and attachments; Oil and gas industries; Power Generation: Flow Controls for the water gates; Motorway repairs and maintenance.

Contact:

**Hydraulic Machines And Spares**  
302 Jay Ganesh CHS Ltd, Bamanpuri Road, J B Nagar  
Andheri (E), Mumbai 400 059  
Mob: 93210 20713 / 81047 68901  
E-mail: hydraulicmachinesandspares.com

## Swing Check Valve Bolted Bonnet

Valve-Tech offers Swing Check Valve Bolted Bonnet. Specifications – Class: 150/300/600; Ends: Flanged/Butt Weld; MOC: WCB/LCB/CF8/CF8M; Trim: CS+ 13% CR/CF8/CF8M; Manufacturing Standard – BS 1868/ANSI B16.34; Test Standard: BS 6755 Part – 1/BS EN 12266 Part 1. Optional Features available: API 6D Design; Ring Joint Facing; Other Trim Material; NACE as per MR-01-75; Counter Weight/Lever/Dash Pot Arrangement; and Size: 50 mm to 750 mm. Valve-Tech also offers Swing Check Valves, Tilting Disc Wafer Check Valve, Lift Check Valve, Butterfly valve, Globe valve, etc.



Contact:

**Valve-Tech Industries**  
Kajal Heritage, Office No: 2, 3 & 4, Sector-12-D  
Plot No: 2A, Koparkhairane, Navi Mumbai 400 709  
☎ 022 – 2754 9193 • Mob: 96994 70055  
E-mail: marketing@vtivalves.com

## Hydraulic & Pneumatic Products

Hindustan Hydraulics & Pneumatics offers a range of Hydraulic products like: Hydraulic Pumps, Directional Control Valves, Flow Control valves, Directional Control Valves,



Pressure Control Valves, Modular Valves, Proportional Valves, Hydraulic Filters, Accumulator, Automatic Lubrication Units, Air Blast Oil Coolers, Heat Exchangers, etc. Pneumatics: Pneumatic Actuators, Direction Control Valves, Flow Control Valves, Process Solenoid Valves, Air Filters, Regulators, Lubricators, Manifolds, Vacuum Ejectors, Vacuum Cups, Rotary Actuators, Grippers, Air Boosters, Air Dryers, Auto Drain Valves, Digital Pressure Switches, Digital Flow Switches, Tubes and Fittings, etc. Manual and Automation Valves: Ball Valves, Butterfly valves, Gate valves, Globe valves, Pressure Relief valves, Pressure Reducing valves, Diaphragm Control valves, Process Solenoid valves, Angle Type Pneumatic Control valves, Non-return Valves, etc. Hoses: Hydraulic hoses, Air and water Rubber hoses, Steam Rubber hoses, SS Corrugated Hoses, SS Braided Teflon hoses, High Pressure Jack Hoses, Nylon Braided PVC hoses, Steel Wire Braided Thunder Hoses, PVC duct hoses, Suction hoses, Fuel Transfer Hoses, Heat Resistant Carbon free hoses, Silicon hoses, etc. Tubes and Fittings: CS, SS, Copper Tubes, Hex Nipple, Male/Female Connector, Male/Female Elbow, Male/Female Tee, Male Branch, Run Tee, Bulkhead, Banjo, Washer, etc.

Contact:

**Hindustan Hydraulics & Pneumatics**  
New No: 265, Old No: 127  
Thambu Chetty Street, Chennai 600 001  
☎ 044 – 2534 3066 / 2534 5625  
E-mail: hhp@hindustanhydraulic.in

## Hydraulic Products

Fluidics Engineers Pvt Ltd offers a range of Hydraulic products like Hydraulic Power Units, Hydraulic Trainer Kit for Colleges and Training Institutes. Their products range includes: Proportional valve, Mobile Controls, Servo Valves, Logic Valves, Directional Controls, Flow Controls, Modular Controls, Gear Pumps, Vane Pumps, ASR, and ASE Pumps, Tie-Road Type medium, pressure pumps, Welded Type Cylinders, Custom built cylinders, etc.

Contact:

**Fluidics Engineers Pvt Ltd**  
12/1 Vetri Vinayagar Nagar, Sivananthapuram,  
Saravanampatti (PO), Coimbatore, Tamil Nadu 641 035  
Telefax: 0422 – 223 6914 • Mob: 98867 71752, 98431 52346  
E-mail: fluides@fluidsmith.com

## ORION Dry Vacuum Pump

Kumark Vacuum Systems Pvt Ltd was established in the year 2000. It started working with ORION Machinery, Japan in the year 2010 as their distributor for Industrial Dry Vacuum Pumps in India and has been offering its various products to meet industrial needs.

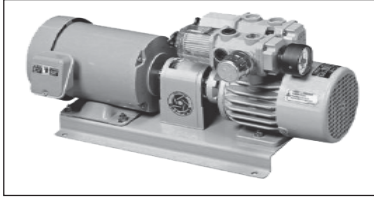

Kumark Vacuum Systems has a very well-proven and highly rich experience of 15 years in the industry. It has been putting its efforts to continue to serve high-quality dry vacuum pumps with a diverse range of capacities. The Company offers ORION KRX Series Dry Vacuum Pumps. Features: No oil in either vacuum, blower or combination application; Quiet operation; Long life; Gauge and controller equipment standard; and Dependable and proven design. Flow Rate: 135 – 1190 L/min. Capacity: Design displacement, logic value is calculated from the cubic volume. The actual flow rate refers to the actual measurement data of performances; It is not allowable to use it at the maximum vacuum reaching point of the pump; Usable range of the degree of vacuum/blower pressure; For the intake air, use clean air of normal temperature and normal humidity whenever possible; Intake air condition: Temperature 0 to 40! and Humidity 65% RH  $\pm$ 20%; The allowable variation range of the supply voltage should be  $\pm$ 10% of rated voltage; Install an overload protector (thermal relays, etc.)

Contact:

**Kumark Vacuum Systems Pvt Ltd**  
TC 32/1727, Sreesailam, Madathuvilakam, PO: Peroorkada  
Thiruvananthapuram, Kerala 695 005  
☎ 0471 – 243 4798 • Mob: 93878 91774  
E-mail: info@inpresvac.com

## Pressure Reducing Valve

Green Manufacturing Co Limited manufactures Pressure Reducing Valve. Features: Test Pressure: 1.6 Mpa; Working Temp from 0°C to 80°C; Screwed Female Ends as per BSP; No External Strainer required as NEU-G PRV has in-built strainers; Working medium: Water. The Company's products range include: Forged Brass Air Release Valve, Butterfly Valve, Multi-Utility Check Valve, Wafer Type Check Valve, Swing Check Valve, Dual Plate Check Valve, etc.



Contact:

**Green Manufacturing Co Limited**  
C-20, Canal Road, Industrial Area, Jalandhar, Punjab 144 004  
☎ 0181 – 506 3236 • Mob: 98881 23236  
E-mail: newpipefittings@gmail.com

## Metal Extrusion Press

Hydraulic Machines And Spares manufactures Metal Extrusion Press for aluminium/copper Gold, silver, etc. The Company designs Press Plants capacity ranging from 100 ton to 2000 ton, and more, depending upon the requirement of the customers. Hydraulic Machines And Spares is a consultant and designer of metal extrusion presses.

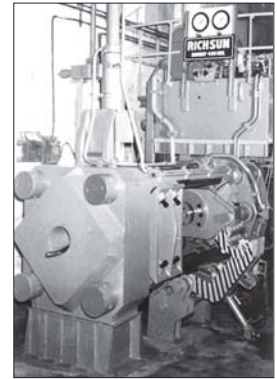

Contact:

**Hydraulic Machines And Spares**  
302 Jay Ganesh CHS Ltd, Bamanpuri Road, J B Nagar  
Andheri (E), Mumbai 400 059  
Mob: 93210 20713 / 81047 68901  
E-mail: hydraulicmachinesandspares.com

## Pneumatic Products

Shree Prayag manufactures a range of Pneumatic Actuators, Fittings, Tubings and other Pneumatic Accessories, Pneumatic Cylinders, Pneumatic One Touch Fittings, Solenoid Valves, Mechanical Valves, Foot Pedal Valves, Push/Pull Hand Draw Valves, Process Control Valves, etc.

Contact:

**Shree Prayag Air Controls (P) Ltd**  
A-56 & A-33, Sector-57, Noida, Uttar Pradesh 201 301  
☎ 0120 – 473 3333 • Mob: 95827 95598  
E-mail: sales@spacpneumatic

## Pipe Fittings

Aaditi Fabricators is a manufacturer and stockist of Carbon Steel, Alloy Steel, and SS Pipe Fittings. Also offers Butt-Weld Pipe Fittings, Flanges, Forged Fittings, Plate Flanges, Tbermo well, Syphon (B/W, S/W End), Industrial Valves under IBR as per customer requirements.

Contact:

**Aaditi Fabricators & Engineers**  
Gala No: 1, Khan Compound, Survey No: 127/1  
Pani Taki Lane, MIDC Taloja, Panvel  
Dist: Raigad, Maharashtra 410 208  
Mob: 98903 32885 • E-mail: aaditifabricators@gmail.com

## Screws Nuts & Bolts

Satya Industries supplies a range of nuts and bolts like SS CSK Slotted Self-Tapping Screws, SS Pan Slotted Self Tapping Screws, SS CSK Phillips Self-Tapping Screws, SS Pan Phillips Self-Tapping Screws, Drywall Gypsum Screw SS 410, SS CSK Slotted Wood Screws, SS CSK Phillips Wood Screws, SS Carriage Bolt with SS Nut etc.

Contact:

**Satya Industries**  
Indl Area, Nr: OP Jindal Modern School, Hisar, Haryana 125 001  
Mob: 775550 57628, 98123 38058  
E-mail: satyaindustriesindia@gmail.com

# Industrial Products Source

A Magazine for Indian Industries since 2004

## SPECIAL SECTION SCHEDULE - May 2024 to March 2025

May	2024	INTEC 2024 Exhibition + Focus: Machine Tools & Automobile Accessories
June	2024	Foundry Equipment, Casting, Forging & Shot Blasting, Boilers & Furnaces
July	2024	Industrial Automation, Instrumentation, Testing & Measuring Instrument
August	2024	Gears & Bearings, Motors & Drives, Clutches & Brakes, Oils & Lubricants
September	2024	Pumps, Valves, Tubes & Pipe Fittings
October	2024	Material Handling & Storage Equipment
November	2024	Electrical & Electronics, Solar, Wind & Alternative Energy
December	2024	21 <sup>st</sup> Annual Issue
January	2025	IMTEX 2025 Exhibition + Focus: Machine Tools & Auto Components
February	2025	Chemical, Pharma, Bio-Tech & Food Processing Packaging, Pollution Control Equipment
March	2025	Cables, Wires, Connectors, Control Panels Transformers Switchgears & Welding Equipment



### Area of Circulation (Industry wise)

- Agriculture
- Air Condition
- Airlines & Aerospace Industries
- Atomic Sector
- Automation
- Automobile
- Bio-Tech & Pharmaceuticals
- Boilers
- Banking Sector
- Cement
- Ceramics
- Chemical Plants
- Construction Machinery & Equipment
- Defence
- Electrical & Electronics
- Exporters
- Fasteners
- Fertilizer
- Food & Beverage
- Foundry & Forgings
- Heat Exchangers & Cooling Towers
- Heavy Engineering
- Hydraulics & Pneumatics
- Industrial Safety & Security
- Libraries
- Machine Tools
- Material Handling
- Oils & Refineries
- Paints
- Paper & Pulp
- Petrochemicals
- Plastic & Rubber
- Pollution Control Boards
- Printing & Packaging
- Project Consultants
- Pumps & Valves
- Railways
- Research Institutions
- Steel
- Sugar / Tea
- Testing Laboratories
- Textiles
- Universities
- Welding

### Advertisement Tariff

Size	4-Color	Black & White
Full Page (17.5 [W] x 25 [H] cm)	₹ 21,000/-	₹ 14,000/-
Half Page (H-17.5 [W] x 12 [H] cm) (V-8.5 [W] x 25 [H] cm)	₹ 12,800/-	₹ 8,500/-
Quarter Page (8.5 [W] x 12 [H] cm)	₹ 7,200/-	₹ 4,800/-
Double Spread (35 [W] x 25 [H] cm)	₹ 42,000/-	₹ 28,000/-
<b>Cover Pages</b>		<b>4 - Color</b>
Front Cover-Half Page (H)	₹ 24,000/-	
Front Cover-Quarter Page	₹ 15,000/-	
Front Cover-Strip (H) (17.5 [W] x 6 [H] cm)	₹ 15,000/-	
Front Inside Cover	₹ 27,000/-	
Back Inside Cover	₹ 27,000/-	
Back Cover	₹ 32,400/-	
Front Gate Fold	₹ 54,000/-	

Home Page	3-Months	6-Months
Small Banner (100 x 100 pixels)	₹ 6,000/-	₹ 10,000/-
Large Banner (240 x 100 pixels)	₹ 8,000/-	₹ 14,000/-
□ Inclusive of Design & Hosting - 12 kb maximum □ If the advertiser wishes to change the design or any updating in the banner will be charged extra		

	Subscription Charges
1-Year (12 Issues)	₹ 300/-
2-Year (24 Issues)	₹ 550/-
3-Year (36 Issues)	₹ 750/-
Outstation payment should be at par cheque/DD drawn in favour of 'Product News Publication' only	

Trim Size: 28 [H] x 21 [W] cms; Bleed Size: 28.6 [H] x 21.6 [W] cms Material Requirement: CorelDraw or PDF Files



Editorial, Circulation & Marketing Office

**Product News Publication**

104, Sudama Yash, Nr: Ramkrishna Hotel, Kelkar Cross Road, Ram Nagar, Dombivli (E), Thane 421 201  
Mobile: 98206 70855 / 98208 38998 • E-mail: ipsmaginfo@gmail.com / ipsmag@yahoo.com

Visit: [www.ips.co.in](http://www.ips.co.in) / [www.industrialproductssource.com](http://www.industrialproductssource.com) to view our e-magazine



# EXHIBITIONS • FAIRS • SEMINARS

## INTEC 2024: International Machine Tool & Industrial Trade Fair



INTEC 2024 is an International Machine Tool & Industrial Trade Fair organized by CODISSIA will be held its 20th edition from 6 to 10 June 2024 at the CODISSIA Trade Fair Complex, Coimbatore, Tamil Nadu.

INTEC is the most sought after event for many companies, which have participated without a break over the years.

It is worth noting that the 20th edition of this event coincides with the Silver Jubilee year of CODISSIA Trade Fair Complex, making it more special and momentous.

Unlike other fairs, being organized by a set of captive and potential buyers, INTEC is the only engineering fair in India in which the sellers get to meet the buying decision makers right away.

In addition, the industries of this region are ever willing to adapt a new technology, which encourages the technology solution providers to participate in INTEC and ever customized solutions to the industries CODISSIA has taken the lead role of bringing together the latest technological developments from all around the globe for ultimate benefit of the Indian Industries and particularly the MSMEs.

### **About CODISSIA Trade Fair Complex:**

CODISSIA Trade Fair Complex was built to create infra-structural facilities needed for conducting Trade fairs, Industrial Exhibitions, Buyer-Seller Meets, Seminars, Conferences, Workshops and such other activities needed for the growth of the regional economy.

Built adjacent to the Coimbatore International Airport, CODISSIA Trade Fair Complex, boasts of more than 20,000



sq. m of covered pillar-free space with heavy-duty flooring and provisions for concealed and underground cabling and with many other state-of-the-art facilities in an area of more than 40 acres of well land-scaped land with more than 80% open area, that leaves the visitors with a pleasant feel the moment they enter the complex.

The Trade Fair Complex is very proximate to the Airport, Railway Station and National Highway.

This region has benefited a lot from INTEC series of trade fairs. Some of the benefits are listed below:

INTEC has put Coimbatore on the world map as a highly competent manufacturing base. INTEC has made Coimbatore the top destination for sourcing components by major industrial houses INTEC enables the local companies to stay updated about technological advancements worldwide.

### **Factors that contribute to the success of INTEC are:**

The success of any outstanding venture depends greatly on the power its promoters possess.

Entrepreneurial spirit of the people of this region and adaptation to new technology by the MSMEs of this region ensures business to all solution providers.

A strong base of over 6700 members of CODISSIA, who are highly potential buyers, encourages exhibitors to participate. These industries formed the major chunk of prospective buyers of machinery and accessories from the exhibitors of INTEC fairs.

Contact:

**Trade Fairs (INTEC 2024)**

☎ 0422 – 222 2396 • Mob: 99655 15182 / 88705 60333

E-mail: [info@codissia.com](mailto:info@codissia.com) • Web: [intec.codissia.com](http://intec.codissia.com)





### Plastics Recycling Show India 2024 Spotighting the Rapid Evolution of India's Plastics Recycling Market

- The inaugural edition of Plastics Recycling Show India to be held from 4th to 6th December 2024 at Bombay Exhibition Centre, Mumbai.
- India's Plastic Recycling Industry is expected to grow from a total market volume of 9.9 million tons to 23.7 million tons by 2032, with a CAGR of 9.86% from 2024-2032.
- The Expo aims to bring together stakeholders in plastics recycling from across India and work on the furthering the conversation around plastics recycling.

Media Fusion and Crain Communications, leading global event organizers, proudly announced the debut edition of the Plastics Recycling Show India 2024 (PRSI) slated to take place at the Hall 4, Bombay Exhibition Centre in Mumbai from 4-6th December 2024. PRSI 2024 marks the entry of the globally renowned Plastics Recycling Show brand into India. With India seeing a total market volume of 9.9 million tons in 2023 and a projection to reach 23.7 million tons by 2032 growing at a CAGR of 9.86% from 2024 to 2032, PRSI 2024 promises to be a pivotal event for industry stakeholders.

Emphasizing the importance of the event, Mr. Taher Patrawala, Managing Director, Media Fusion, said "As we witness a global shift towards sustainable practices, it's imperative for nations to address the pressing issue of plastic pollution. With the Indian government's proactive measures, including the ban on various single-use plastic items and the implementation of Extended Producer Responsibility (EPR) regulations, the stage is set for significant strides in plastic waste management.

The launch of Plastics Recycling Show India (PRSI) marks a pivotal moment in our commitment to tackling this challenge head-on. Bringing PRS to India after successful editions in the Middle East and Europe underscores the nation's dedication to fostering a sustainable future and aligns with government initiatives aimed at promoting responsible plastic usage and waste management."

The three-day expo and high-level plastics recycling and sustainable packaging conference will unite delegates, thought leaders, innovators, and technology providers in the plastics recycling industry, fostering collaborations, and driving meaningful progress towards a sustainable future. Suppliers, manufacturers, technology specialists, waste managers, consultants, and emerging players in the industry will convene to explore business opportunities under one roof.

At the conference that runs alongside the show, interna-



tional experts will address key themes including circular economy principles, sustainable packaging, regulations, challenges, opportunities, innovations, technologies and trends, and share insights and experiences from across the plastics sector to promote a green future.

The unveiling of PRSI 2024 followed an illuminating roundtable conference held in Mumbai, where industry thought leaders converged to address the pressing challenges and opportunities in plastics recycling. Esteemed panelists including representatives from the Bureau of Indian Standards, Alliance to End Plastic Waste, INDIAN PLASTICS INSTITUTE – IPI, Mumbai Sustainability Centre, Brihanmumbai Municipal Corporation and other influential stakeholders, engaged in insightful discussions on enhancing recycling infrastructure, incentivization of waste management, deficiencies within the sector, streamlining regulatory frameworks, and fostering collaboration across the value chain. The discussion highlighted the unique challenges specific to Mumbai and underscored the importance of collective action in addressing them.

Speaking on the occasion, Mr Matthew Barber, Global Events Director, Crain Communications said, "PRS is globally recognised as a brand – known for its expertise in bringing together the entire plastics recycling value chain on one platform in Europe, the Middle East and South-East Asia. The PRS Show has been growing since its inauguration in Europe in 2015. Building on the success of PRS in Europe and the Middle East, we are elated to bring PRS to India. With legislation mandating certain criteria, there is a pressing need to explore industry practices to meet this target."

India's plastics industry serves as a key economic growth driver, contributing significantly across sectors such as automotive, construction, electronics, healthcare, textiles, and FMCG. With India's plastic recycling of average 13%



## EXHIBITIONS ● FAIRS ● SEMINARS

surpassing the global average of 9% and outperforming some developed economies that only recycled 4%, the nation's ambitious recycling approach aims to inspire global leaders in combating plastic pollution.

As the first-ever dedicated platform for the plastics recycling industry in India, PRSI 2024 promises to catalyze

innovation, foster partnerships, and drive meaningful change towards a circular economy.

Contact:

**Media Fusion**

**50/A3-2, Palace Road, Bengaluru, Karnataka 560 052**

**☎ 080 - 4112 5594, 2225 4850**

### EuroBLECH 2024: The Power of Productivity

The global flagship event on sheet metal working is expecting a huge turnout this year. Spread over nine exhibition halls and covering more than 90,000 square metres, this year's event will be a unique opportunity to see the largest collection of sheet metal working technology in one place. Six months ahead of the show, over 90% of available stand space has already been secured. New this year are the Guided Visitor Tours showcasing the top picks in productivity solutions to increase output and efficiency.

From 22 to 25 October 2024, the 27th International Sheet Metal Working Technology Exhibition, EuroBLECH, will open its doors again at the Hanover Exhibition Grounds in Germany. It is the world's largest exhibition for sheet metal processing, covering the entire supply chain in 15 different technology sectors. Visitors can look forward to an impressive amount of live demonstrations and world premieres, giving opportunity to explore, assess and discuss the benefits and gains of specific technology solutions for their own production process.

EuroBLECH 2024 will be occupying halls 11, 12, 13, 14, 15, 16, 17, 26 and 27 at Hanover Exhibition Grounds, the world's largest exhibition centre. The uptake on stand space has been immense, in particular from international exhibitors, with more than 60% of exhibitors joining from outside Germany. As such, the show mirrors the global significance of the sheet metal sector in the wider economy. Besides Germany, the major exhibitor countries are Italy, Turkey, China, Spain, the Netherlands, Switzerland, Taiwan, Belgium, Austria, France and the USA.

#### **Live on the show floor: Smart machinery, tools and IT solutions**

EuroBLECH provides numerous opportunities to watch innovative machinery live in action. It is worth noticing that more than a quarter of EuroBLECH visitors do not attend any other trade shows – they feel EuroBLECH already offers the best access to the broadest possible spectrum of tech suppliers, with exhibits covering literal-

ly anything to do with the processing of metal sheet, tubes, profiles, plastic hybrids and other related applications.

**On display:** Stamping presses, CNC punching machines, press brakes and other machines and tools for cutting, punching and forming; joining; welding and fastening; surface treatment and finishing; process control and quality assurance; machine elements and components; CAD/CAM/CIM systems; warehouse and factory equipment; material recycling; and much more.

#### **New for 2024: Guided Visitor Tours**

For the first time, visitors will be able to book carefully curated visitor tours. Also reflected in this year's motto for EuroBLECH, 'The Power of Productivity', the organised visitor experiences focus on productivity-enhancing technology. The tours will include 10-minute presentations at each stop, followed by a short Q&A session. There are two different tour options to choose from:

**Tour 1** "Industrial Internet of Things (IIoT)" covers key topics such as big data, remote analysis, predictive maintenance, production monitoring, and part traceability. Participants will discover various products, tools and software to help them plan, optimise and monitor production with a view to improving their overall productivity, efficiency and sustainability.

**Tour 2** "Automation and Robotics for Efficient Production" demonstrates how integrated, bolt-on or stand-alone automation and robotics systems can streamline production operations for greater sustainability and productivity, even for small batches. These can range from handling, sorting, conveyor, storage, and stacking systems to robots, co-bots and autonomous mobile robots (AMRs).

Further information on how to book the Guided Visitor Tours will be published on the EuroBLECH website closer to the show.

#### **EuroBLECH 2024 Speaker Forum for valuable insights**



## EXHIBITIONS ● FAIRS ● SEMINARS

In addition to the innovations and numerous live demonstrations on the exhibition stands, attendees can benefit from the popular EuroBLECH 2024 Speaker Forum, two dedicated presentation theatres for expert talks and panel discussions. Sessions run on all four show days and offer exciting insights into the latest projects and product developments, as well as valuable networking opportunities and meaningful exchange amongst peers. The speaker agenda will be published closer to the show.

### **EuroBLECH 2024 Industry Awards for technical excellence**

The prestigious EuroBLECH Industry Awards are making a comeback at EuroBLECH 2024. Recognition will be given for the most innovative products, solutions and digitalisation concepts in various categories. The winners will be selected by industry professionals via online voting, starting in autumn 2024 and the awards will be presented at the exhibition. More details will be published in the run-up to the show.

### **Last minute stand bookings**

Over 90% of available stand space has already been

booked. Companies planning to present their products this year are advised to contact the Show Team immediately. All relevant exhibitor information can be found on the show website. Available stand options include the **myEuroBLECH Easy Package** with a shell scheme offer and the super convenient **First Time Exhibitor Package** which includes a turnkey solution plus marketing package to a very competitive price. Visit: [www.euroblech.com](http://www.euroblech.com)

### **About RX**

RX is a global leader in events and exhibitions, leveraging industry expertise, data, and technology to build businesses for individuals, communities, and organisations. With a presence in 25 countries across 42 industry sectors, RX hosts approximately 350 events annually. RX is committed to creating an inclusive work environment for all our people. RX empowers businesses to thrive by leveraging data-driven insights and digital solutions. RX is part of RELX, a global provider of information-based analytics and decision tools for professional and business customers.

For more information, visit [www.rxglobal.com](http://www.rxglobal.com)

## **Attention Readers...**

*If you are a manufacturer or dealer of any industrial product,  
we invite you to  
send your Product write-ups for Free publication,  
in about 200 words describing the product, such as  
its technical specifications, special features, applications, etc,  
along with a clear photograph of the product to:*

**[ipseditor@gmail.com](mailto:ipseditor@gmail.com) or**

*The Editor*

## **Industrial Products Source**

**Product News Publication**

104, Sudama Yash, Kelkar Cross Road

Nr: Ramkrishna Hotel, Ram Nagar, Dombivili (E), Thane 421 201



## Rösler PowerLine valve – the first blast media flow control based on AI

### By automatically optimizing shot blasting processes an “intelligent” shell valve significantly improves cost efficiency

*With its innovative PowerLine valve Rösler achieves a substantial improvement in turbine shot blasting operations. The recently developed “intelligent” shell valve ensures that the blast intensity of the turbines is automatically adjusted to different shot blasting requirements. This ensures optimal operating conditions. The adjustment takes place independently from the turbine RPM and without time consuming manual adjustment of the blast media flow. Therefore, equipment malfunctions and operator errors are more or less completely eliminated, and the overall process and equipment safety is significantly improved. This process optimization, along with a lower blast media consumption and lower energy input, results in a high cost-efficiency of the shot blasting process.*

The turbines are without doubt the centerpiece of shot blast machines and determine to a large extent the blast performance, the required cycle times and the costs of a shot blast process. Until now - during the commissioning of a new blast machine, the creation of work piece specific programs, a blast media change and during maintenance work - time consuming adjustments of the blast media flow were required to achieve optimal operating conditions. In this respect the turbine speed (RPM) plays an essential role: If, for whatever reason, the turbine speed is reduced, it decreases the amperage draw and the blast media throughput. The new, “intelligent” shell valve from Rösler allows the automatic, optimal adjustment and control of the blast performance independently from the turbine RPM. The partially manual and error-prone adjustment of the shell valve is, therefore, a thing of the past!

#### **AI makes the first self-teaching blast media flow control possible**

At the heart of this new, patent pending system is an innovative shell valve. Through special sensors the valve opening is automatically adjusted to the specified blast media flow. For the determination of the opening a special software was developed that takes the parameters amperage draw, throwing speed and blast media flow into consideration. One feature of this software is that, with the menu “setting of the blast media flow” it allows the automatic creation of separate programs for each turbine within a few minutes. Manual adjustments are no longer

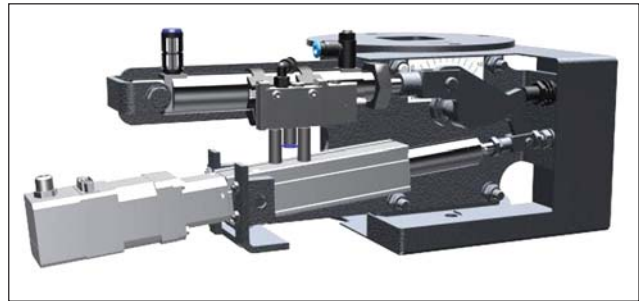

required. All the operator has to do is enter the optimal operating parameters for the respective shot blast process, such as throwing speed, blast media flow or amperage draw, at the operating panel. If, for example, a high work piece throughput is required, the operator can simply increase the blast media flow and the throwing speed. At the same time, for processing delicate work pieces, it

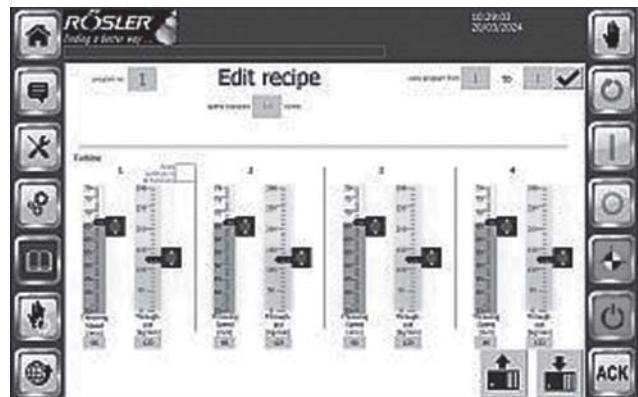

is possible to reduce the media flow and throwing speed to a value that prevents damage to the work pieces.

#### **Faster, more stable shot blasting processes with lower energy input**

In everyday shot blasting operations the new Rösler

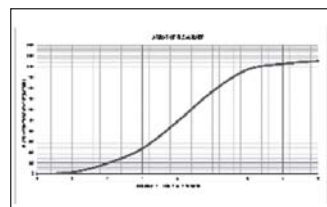

PowerLine valve results in shorter cycle times. The complicated and time-consuming adjustment of the shell is no longer required. Equipment malfunctions and operator errors have practically been completely eliminat-

ed, and the shot blasting processes run with a higher degree of stability and consistency. Therefore, unplanned equipment downtimes can to a large extent be prevented. At the same time this “Intelligent” solution produces significant energy savings. Moreover, individual shot blast programs for new work pieces can be easily created and saved in the PLC. And finally, complex shot blast processes requiring different blast media flow quantities can be quickly implemented without any problems. For example, for the de-sanding of castings the process usually starts with a relatively low blast media flow, which is then gradually increased. This ensures that the sand carried into the blast machine with the castings is safely and effectively separated from the blast media, and the

castings are properly cleaned. Compared to traditional de-sanding operations, where some turbines are sequentially turned on and off, the PowerLine valve helps to significantly decrease the cycle times.

The Rösler system also offers substantial advantages for shot peening operations with short cycle times by drastically reducing the setup times for the respective peening process. An additional benefit is the automatic monitoring and documentation of the blast media flow. It provides proof that a given shot blast process has been run with precisely defined parameters. The new Rösler PowerLine valve is available as a separate option and is also available in the Smart Solutions package. [www.rosler.com](http://www.rosler.com)

---

## RR Kabel brings brilliance home: Luminous Fans’ makeover to RR Signature showcased in TVC campaign with #AapkeKaamKiBaat

*~RR Signature Fans offer perfect home solution with 60% energy saving, RF remote, In-Built Stabilizer (100 to 300 V) ~*

R R Kabel Limited, one of India’s leading wire and cable manufacturers, proudly announces the rebranding of Luminous Fans to RR Signature Fans. Coinciding with the onset of summer in India, RR Signature Fans introduce a 24-second TVC campaign with the hashtag #AapkeKaamKiBaat, highlighting their unparalleled features and benefits. These fans fall under the RR Kabel product portfolio, ensuring a seamless transition for customers while retaining the essence of quality and reliability associated with Luminous. This strategic move follows RR Kabel’s acquisition of Luminous Power’s home electrical business (HEB) in April 2022.

The acquisition of Luminous’ HEB was a pivotal step for RR Kabel, aimed at fortifying its consumer electrical business. With a diversified portfolio encompassing fans, lights, and appliances, RR Kabel is poised to make significant strides in the premium segment of the industry. Luminous’ HEB, renowned for its innovative designs and energy-efficient solutions, including star-rated premium designer fans, has paved the way for RR Kabel to expand its offerings and cater to the discerning needs of consumers in India.

RR Signature Fans, the latest addition to RR Kabel’s portfolio, offer unmatched features. These fans are up to 60% energy-saving, feature an RF remote, and comes

equipped with an in-built stabilizer, capable of operating within a voltage range of 100-300 V.

To view the TVC, please visit: [YouTube](#) | [Instagram](#) | [Facebook](#) | [LinkedIn](#)

*“We are excited to unveil RR Signature Fans as a testament to our commitment to innovation and excellence in the consumer electrical segment. Everyone has a different style, taste, and perspective, and when it comes to decorating homes, each individual loves to add their personal touch and express their unique sense of beauty. With this understanding, RR Kabel brings you an extensive range of RR Signature Fans, offering unparalleled features that cater to the evolving needs of our customers. Our innovative technology, combined with aesthetically pleasing design, allow you to decorate your home and experience the warmth of delight”,* said Mr Shreegopal Kabra, Managing Director at R R Kabel Limited.

RR Signature Fans will continue to embody the legacy of Luminous, while leveraging RR Kabel’s extensive resources and expertise to push boundaries and set new benchmarks in the premium fan segment.

R R Kabel Limited is India’s largest exporter of wires and cables, and spread across multiple business verticals including Fans, Lighting, Switches, Switchgears and Appliances.

Visit: [www.rrkabel.com](http://www.rrkabel.com)

## REC Wins SKOCH ESG Award 2024 in Renewable Energy Financing Category



REC Limited, a Maharatna CPSE under the Ministry of Power and a leading NBFC, has been bestowed with the SKOCH ESG Award 2024 in the 'Renewable Energy Financing' category. The award recognizes REC's commitment towards sustainable finance, driving progress towards a greener future. Shri TSC Bosh, Executive Director, REC Limited, received the award in New Delhi.

This accolade underscores REC's dedication to sustainable financing, paving the way for a greener future and accelerating the transition to renewable energy. REC has emerged as a significant player in India's clean energy transition, actively contributing to the nation's sustainable future. Through various initiatives and achievements, REC has committed to numerous sustainable projects and signed various MOUs for green projects.

Furthermore, REC has engaged in one-on-one discussions with various developers of green projects, spanning sectors such as solar, wind, PSPs, E-mobility, RE manufacturing, Green ammonia/hydrogen, and battery storage. Looking ahead, REC anticipates a significant expansion in its renewable energy portfolio, with projections indicating growth to 10 times its present value, reaching more than ₹3 lac crore by 2030, representing approximately 30% of its AUM.

The SKOCH ESG Awards recognize organizations that demonstrate outstanding performance in Environmental, Social, and Governance (ESG) practices. The SKOCH ESG

Award and Assessment serve as an important benchmark for evaluating organizations' commitment to India 2047. It focuses on the interplay between sustainable investments and processes to shape a sustainable and growing business future.

**About REC Limited** – REC is a 'Maharatna' CPSE under the Ministry of Power, and is registered with RBI as Non-Banking Finance Company (NBFC), and Infrastructure Financing Company (IFC). REC is financing the entire Power-Infrastructure sector comprising Generation, Transmission, Distribution, Renewable Energy and new technologies like Electric Vehicles, Battery Storage, Pumped Storage projects, Green Hydrogen, Green Ammonia projects etc. Recently, REC has also diversified into the Non-Power Infrastructure sector comprising Roads and Expressways, Metro Rail, Airports, IT Communication, Social and Commercial Infrastructure (Educational Institutions, Hospitals), Ports and Electro-Mechanical (E&M) works in respect of various other sectors like Steel, Refinery, etc.

REC Ltd provides loans of various maturities to State, Central and Private Companies for creation of infrastructure assets in the country. REC Ltd continues to play a key strategic role in the flagship schemes of the Government for the power sector and has been a nodal agency for Pradhan Mantri Sahaj Bijli Har Ghar Yojana (SAUBHAGAYA), Deen Dayal Upadhaya Gram Jyoti Yojana (DDUGJY), National Electricity Fund (NEF) Scheme which resulted in strengthening of last mile distribution system, 100% village electrification and household electrification in the country.

REC has also been made the nodal agency for certain States and Union Territories for the Revamped Distribution Sector Scheme (RDSS). REC has also been given the responsibility of PM Surya Ghar Muft Bijli Yojna from Central Government. The loan book of REC stands at ₹4.97 Lakh crores and Net Worth at ₹64,787 crores as on 31st Dec, 2023.

Contact:

**REC Limited**

☎ 0124 – 444 1300 • E-mail: [recccprco@gmail.com](mailto:recccprco@gmail.com)

Website: [www.recindia.nic.in](http://www.recindia.nic.in)

**Subscribe to  
Industrial Products Source at ₹300/- for 1-year.**

## RECPDCL hands over Kallam Transco Limited SPV to Indigrd & Jalpura Khurja Power Transmission Limited SPV to Tata Power

REC Power Development and Consultancy Limited (RECPDCL), a wholly owned subsidiary of REC Limited - a Maharatna CPSU under the Ministry of Power and a leading NBFC, handed over two project specific SPVs (Special Purpose Vehicles) on Friday, 4th April 2014, namely, Kallam Transco Limited and Jalpura Khurja Power Transmission Limited formed for “Western Region Network Expansion Scheme in Kallam area of Maharashtra” and “Construction of 400/220 kV, 2×500 MVA GIS substation Metro Depot (Gr. Noida) with associated lines and 400/220 kV, 2×500 MVA GIS substation Jalpura” respectively through tariff based bidding process.

Indigrd 2 Limited and Indigrd 1 Limited (Consortium) was the successful bidder for the Inter State Transmission Project of Ministry of Power, Government of India for development of Western Region Network Expansion Scheme in Kallam area of Maharashtra and The Tata Power Company Limited was the successful bidder for the Intra-state project for Construction of 400/220 kV, 2×500 MVA GIS substation Metro Depot (Gr. Noida) with associated lines and 400/220 kV, 2×500 MVA GIS substation Jalpura of Govt. of Uttar Pradesh.

RECPDCL was the Bid Process Coordinator for both the projects.

The SPVs were handed over to the bidders in presence of Shri Rajesh Kumar, CEO, RECPDCL and senior officials of RECPDCL, REC Limited, CTUIL & UPPTCL.

**About RECPDCL:** REC Power Development and Consultancy Limited, RECPDCL, a wholly owned subsidiary of REC Limited, has been providing knowledge based consultancy and expert project implementation services to more than 50 State power distribution companies/Power Departments of States. RECPDCL has been acting as Bid Process Coordinator (BPC) for Tariff Based Competitive Bidding (TBCB) in Transmission Line Projects & RE-Bundling projects. Under PMDP projects RECPDCL has been executing critical infrastructure upgradation projects in distribution and transmission sectors in the UT of J&K and Ladakh. RECPDCL with its expert consulting, project implementation and transaction advisory services is thus playing a key role across the power sector value chain of the country.

**About REC Limited:** REC is a ‘Maharatna’ CPSE un-



der the Ministry of Power, and is registered with RBI as Non-Banking Finance Company (NBFC), and Infrastructure Financing Company (IFC). REC is financing the entire Power-Infrastructure sector comprising Generation, Transmission, Distribution, Renewable Energy and new technologies like Electric Vehicles, Battery Storage, Pumped Storage projects, Green Hydrogen, Green Ammonia projects etc. Recently, REC has also diversified into the Non-Power Infrastructure sector comprising Roads & Expressways, Metro Rail, Airports, IT Communication, Social and Commercial Infrastructure (Educational Institution, Hospitals), Ports and Electro-Mechanical (E&M) works in respect of various other sectors like Steel, Refinery, etc. REC Ltd. provides loans of various maturities to State, Central and Private Companies for creation of infrastructure assets in the country. REC Ltd. continues to play a key strategic role in the flagship schemes of the Government for the power sector and has been a nodal agency for Pradhan Mantri Sahaj Bijli Har Ghar Yojana (SAUBHAGAYA), Deen Dayal Upadhaya Gram Jyoti Yojana (DDUGJY), National Electricity Fund (NEF) Scheme which resulted in strengthening of last mile distribution system, 100% village electrification and household electrification in the country. REC has also been made the nodal agency for certain States and Union Territories for the Revamped Distribution Sector Scheme (RDSS). REC has also been given the responsibility of PM Surya Ghar Muft Bijli Yojna from Central Government. The loan book of REC stands at Rs 4.97 Lakh Crore and Net Worth at Rs. 64,787 crores as on 31st Dec, 2023.

## ELGi Introduces the EG Super Premium range of Oil-Lubricated Screw Air Compressors

*Expands renowned EG series to offer customers industry leading energy efficiency with low lifecycle costs*

Elgi Equipments (BSE: 522074 NSE: ELGIEQUIP), one of the world's leading air compressor manufacturers, has introduced the EG SP (Super Premium), upgrading the world renowned EG Series portfolio of oil-lubricated screw air compressors. These machines represent a notable advancement in compressed air technology, offering customers significant energy efficiency gains of up to 15%, best-in-class warranty and performance, with low life cycle costs in the 90-110kW compressor range.



EG Super Premium Series A

The upgraded ELGi EG SP units embody newly configured two-stage airends, featuring the proven  $\zeta$ -V profile, which optimises the overall compression process, resulting in up to 15% savings in specific power consumption. Coupled with low-speed airends and a lighter load on each stage, this ensures extended component lifespan. Aside, the IE4 super premium motors, enable seamless integration of advanced design and cutting-edge technology, resulting in increased energy efficiency. All EG Super Premium machines are also equipped with the Neuron 4 industrial controllers which guarantee optimal performance. The EG super premium also features a unique oil filter designed for prolonged 4000-hour lifespans; the filter efficiently removes contaminants from the compressor's lubrication system, emphasizing exceptional durability and overall longevity. In addition, all EG super premium units are compatible with Air~Alert, ELGi's add-on IoT solution, which when integrated with the Neuron 4 controller, transforms compressor management by elevating uptime, energy efficiency, and enabling 24x7 global remote monitoring.

Bhavesh Karia, President, ISAAME (India, South Asia, Africa, and the Middle East) and SEA (Southeast Asia), Elgi Equipments Limited, said, "At ELGi, our unwavering commitment lies in aligning technological progress with tangible efficiency gains for our customers and the



EG Super Premium Series B

environment. With the EG Super Premium, we have taken a stride forward in our quest to deliver heightened performance, while setting new benchmarks for efficiency and dependability in compressed air technology.

Recognizing that over 80% of a compressor's total lifecycle cost is attributed to energy costs, the EG Super Premium compressors deliver an impressive boost of up to 15% in energy efficiency. Tailored for manufacturing enterprises emphasizing energy efficiency and environmental stewardship, these cutting-edge units promise substantial energy savings through their innovative features bundled in a highly competitive total cost of ownership package."

Every EG Super Premium compressor comes with a standard warranty of 6 years for the airend, 3 years for critical parts and one year on the package and an extended warranty of 10\* years for the airend and 5\* years on the package (\*Terms & Conditions apply). The ELGi EG Super Premium is built to ensure long life, reliability, and durability.

### About ELGi:

Elgi Equipments Limited is a global air compressor manufacturer with a broad line of innovative and technologically superior compressed air systems. ELGi has consistently worked towards ensuring that its customers achieve their productivity goals while keeping the cost of ownership low. ELGi offers a complete range of compressed air solutions, from oil-lubricated and oil-free rotary screw compressors, oil-lubricated and oil-free reciprocating compressors, and centrifugal compressors to dryers, filters, and downstream accessories. The company's portfolio of over 400 products has found wide application across industries. For further information on the organisation and its products, please visit <http://www.elgi.com>

**Subscribe to  
Industrial Products Source at ₹550/- for 2-year.**

# Products INDEX

<b>A</b>		By-Pass Rotameter	13
AC to AC Solid State Relay	25	<b>C</b>	
Acrylic Body Manometers	15	Cable Trolley	c-i
Aerial Bunched Cables	c-ii	Cables & Wires	c-ii
Air Driven Liquid Pumps	21	Capacitance Type Level Transmitters	13
Air Filter-cum-Pressure Regulator	38	Cartonator Pockets	4
Air Velocity Kit	13	CCT / Cat-5 / LAN Cables	c-ii
Airless 4 W Tunnel Type Blasting Machine for Sheet Blasting	c-i	Centrifugal Chemical Process Pump Match III	27
Alkaline Based Descaling Chemical	28	Centrifugal Monoblock Pump	24
All Kinds of Other Special Cables	c-ii	Ceramics for Fluid Handling Applications	40
Alloy Steels	3	Ceramics for Pump Industry	37
Angle Valves	35	Check Valves	7
Apron Feeders / Conveyors	c-iii	Chemical Pumps	17
Automated Reference Method Sampler	c-iii	Chemical Sealed Gauges	11
Automatic Cone Making Machine	5	Chemical Storage, Reaction, Transport Tanks & Vessels	34
Automatic Hi-Speed Triple Head Container Filling Machine	27	Chemicals	31
Automatic Rotary Glass/Pet Bottle Washing Machine	33	Clamps for Photo Cells	4
<b>B</b>		Clean Room High Speed Doors	41
Ball Valve, 3-Piece Flanged End	37	Clear Water Pumps	36
Band Dryer	30	Co-Axial / Instrumentation / Computer Cables	c-ii
Barometer	13	Coiled & Disc Springs	3
Barrel Pump	17	Cold Work Tool Steels	3
Belt Conveyors	c-iii	Commercial Gauges	11
Belt Conveyors, Pipe Conveyors	c-iii	Compact or Package Substation	16
Bi-Metallic Temperature Gauges	11	Compact Sealed Gauges	11
Bipod	4	Comparison Tester	11
Blast Room and Paint Room System Supplied for Rail Chassis Body	c-i	Conductivity Level Switches	13
Borewell Pump	29	Cone Crusher	c-iii
Brackets & Guides	4	Control & Relay Panel	32
Brute Force Screen	c-iii	Conveyors & Components	4
Bucket Elevators	c-iii	Coolant Pumps VDS/VDC Series	14
Butterfly Valves	20	Cooling Tower GCT Series	31
		Corn Flake Dryer Heater	29
		Crane Limit Switches	c-i

<b>D</b>		Gauge Saver	11
Die Steels	3	Gear Oils	32
Digital Pressure Gauges + Transmitter	13	Gear Pumps	17
Digital Pressure Gauges	13	Glass Tube/Acrylic Rotameters	13
Digital Pressure Switches	13	<b>H</b>	
Direct Drive Pump	17	HDA Series Mounts	21
Dyes, Pigments & Textile Chemical	24	Heavy Duty Bucket Elevator	c-iii
<b>E</b>		High Frequency Screen	c-iii
Economical Gauges	11	High Pressure Hydrotesting Pumps	38
Edge Protector Making Plant	25	Homogenizer Gauges	11
Effluent Treatment Plant	26	Hook-up Wires	c-ii
Eight Channel Temperature Data Logger		Hot Work Tool Steels	3
with Direct USB Pen Drive Output	5	House Wiring / Multicore Cables	c-ii
Electric Actuated Butterfly Valve	16	Hybrid Servo Hydraulic System	26
Electrical Insulation Rubber Matting	18	Hydraulic & Pneumatic Products	42
Electro Hydraulic CNC Press Brake	34	Hydraulic and LPG Hoses	21
Electromagnetic Flowmeter	13	Hydraulic Bending Press	29
EOT Crane Components	c-i	Hydraulic Clamping Systems	15
Exhibitions	9, 45, 46, 47 & 48	Hydraulic Fixture	28
<b>F</b>		Hydraulic Presses	42
Flame Retardant & Smoke Suppressant		Hydraulic Products	12, 31 & 42
Chemicals FAM-501	39	Hydraulic Self-Centering Steady Rest	20
Flanges	8	Hydraulic Test Pump	17
Flat Submersible Cables (3 Core)	c-ii & 23	Hydraulic Thruster Brakes	c-i
Flexible / Industrial Cables	c-ii	<b>I</b>	
Float & Board Level Indicators	c-i	Idlers, Rollers & Pulleys	c-iii
Float Valves	24	Impact Hammer Crusher	c-iii
Flow Indicators	c-i	Impact Sockets	3
Flow Switches	13 & 21	Incremental Rotary Encoders	20
Fluid Bed Dryer	32	Industrial Burners	4
Forged Brass Ball Valve	30	Industrial Dual Block Burners	4
Forging Components	3	Industrial Gauges	11
FR / FRLS / PVC Cables		Industrial Limpet Reactor	33
(HT & LT Cables)	c-ii	Industrial Valves	19
<b>G</b>		Industrial Ventilation Coolers	22
Gas/Heavy Oil Burners	4	<b>K</b>	
Gas/Light Oil Burners	4	Kewaunee Flammable Storage Cabinets	18
Gate Valves	41	KirloSmart IoT Remote Monitoring Solutions	13

Kitz Butterfly Valves	36	<b>P</b>	
<b>L</b>		Paper Conversion Machinery	5
Laboratory Instruments, Hospital Furniture & Glassware	40	Paper Tube Production Line	5
LAN Cables	c-ii	Pharmaceutical Machines	34
Level Instruments	c-i	Phosphorous Chemicals	21
Liquid Column Manometers	13	Pipe Conveyors	c-iii & 15
Liquid Level Indicators	13	Pipe Fittings	43
Liquid Level Switches (Float Operated)	13	Pipes & Fittings	8 & 22
Liquid Level Transmitter	13	Plastic Mould Steels	3
Low Pressure Capsule Gauges	11	Pneumatic Cylinders	24
LUBERR LUX Pumps	12	Pneumatic Products	19 & 43
<b>M</b>		Pneumatic Tools & Accessories	19
Magnetic Level Indicators	c-i	Power & Control Cables (Aluminium / Copper / Conductor / Armoured Unarmoured Cables)	c-ii
Manometers	c-i	Power Cables	13
Measuring Instruments	13	Precision Cold Forging/Cold Extrusion Hydraulic Presses, 4-Column Type	27
Membrane Filter Holder	37	Precision Tubes	16
Metal Extrusion Press	43	Preservation Line Inline Blasting, Painting and Baking System	c-i
Metal Tube Rotameter with Transmitter / Flow Indicator Totalizer	13	Pressure Booster Pumps, SCM Series	20
Modular NC Plasma Cutting Machine, Table Type	14	Pressure Gauges	11
Modular Supports	4	Pressure Reducing Valve	43
Moulded Plugs	c-ii	Pressure Switches	13
Mud Gauges	11	Process Instruments	13
Multistage Pumps	35	Process Pumps EO/EOS Series	14
Multivane Oil Lubricated Pump	7	Pulse Jet Bag Filter	c-iii
<b>N</b>		Pumps & Systems	31
Needle Valves	11	Purge Set	32
Non-Clog Submersible Pump	33	PVC Insulated Industrial Wires & Cables	c-ii
Non-Destructive Headspace Oxygen Analyzer	22	<b>R</b>	
NOP Filter Pump	35	Rail Clamps	c-i
<b>O</b>		Reflex & Tubular Level Gauges	c-i
Oil Free Diaphragm Type Vacuum Pressure Pumps	27	Reflex Transparent Boiler Gauges	c-i
Oil/Gas/Dual Fuel Burners	4	Research Chemicals	10
ORION Dry Vacuum Pump	43	Resistance Box	c-i
		Resonance Screen	c-iii



Reversible Hammer Crusher	8	Special Shot Blasting Machine for Cleaning	
Roots Vacuum Pumps	30	of Submersible Pump Casing	c-i
Rotary Airlock Valve	33	Special Shot Blasting Machine for Fold-away	
Rotary Gear Pump	c-iv	Tray of Sheet Molding Compound	c-i
Rotary Gear Pump, Type HGSX	30	Special Shot Blasting Machine for Gear	
Rotary Gear SS Pump	c-iv	Cutters Tools before PVD Coating	c-i
Rotary Jacketed Pump	c-iv	Specialised Cables	18
Rotary Main Oil Pump	c-iv	Specialty Chemicals	25
Rotary Monoblock Pump	c-iv	Spray Dryer	12
Rotary Tracodial Pump	c-iv	Spring Steels	3
Rotary Triple Twin Gear Pump	c-iv	Square & Round Bars	3
Rotary Triple Twin Gear Pump Type		SS Magnetic Process Pump	17
NDX Series	15	Stainless Steel	37
Rotary Twin Gear Pump	c-iv	Submerged Sump Pumps for	
Rotary Twin Gear Pump, Type RDRN	6	High Temperatures	28
<b>S</b>		Submersible Borewell Pumps	5
Samples & Sampling Systems	c-iii	Submersible Portable Pumps, PST Series	39
Self-Priming Non-Clog Pump	17	Submersible Pumps	23
Self-Priming Non-Clog Muddy Water Pump	17	Submersible Sewage Pumps	8 & 16
Screw Conveyors	c-iii & 17	Surface Finishing Solution	c-i
Screws Nuts and Bolts	43	Swimming Pool Heat Pumps	37
Seal-Less Magnetic Pump	17	Swing Check Valve Bolted Bonnet	42
Self Priming Multistage Boiler Feed Pump	17	Switches	c-i
Servo Controlled Hydraulic Press Brake		Synthetic Heat Transfer Fluid,	
2-Axis Model HPB-S	11	Maxothermie-550S™	6
Sidewall High Angle Conveyor	c-iii	Syphons	11
Siemens Process Instruments	c-i	Syrup Manufacturing Plant	40
Sight Flow Indicator	14	<b>T</b>	
Sight Glasses	c-i	T+RH and Differential Pressure	
Silica Fume (Micro Silica)	23	Transmitters	12
Single Toggle Jaw Crusher	c-iii	Teflon Lined Pumps	26
Sludge Pump System, Smartec	18	Telecommunication Cables	c-ii
Soft Seated 2-Piece Ball Valve	40	Temperature Gauges	11
Solar Cables	c-ii	Temperature Measuring Instruments &	
Solenoid Valve Connectors	25	Allied Products	13
Special Automatic Shot Blasting Machine for		Testing Equipments & Accessories	11
Internal and External Cleaning of		Thread Rolling Machines	34
Submersible Pump Casing	10	Three Core Flat Submersible Cables	c-ii

Thruster Brakes	c-i	Vertical Multistage Pumps	17
Tool & Alloy-Special Steels	3	Vertical Shaft Impactor	c-iii
Tools – Collets	3	Vertical Sump Pump	17
Transmitters	c-i	Vertical Turbine Pumps – SVT	36
Triclover Sealed Gauges	11	Vibrating Feeder	c-iii
Tripod	4	Vibrating Grizzly Feeder	c-iii
TRS / TRS Braided / Welding Cables	c-ii	Vibro Shifter	28
Tubings & Fittings	40	V-Notch Ball Control Valves (Series 300)	35
Twin Screw Pumps	36	Voltage Tester Model KM 66/KM 69	11
Two-Stage Gas Burners Class III with Built-in Inverter	39	<b>W</b> Water Bath	7
<b>V</b>		Welded Tubes Pipes	38
Vacuum Manometer	13	Welded Type Cylinders	39
Vacuum Pumps	7 & 23	Wire Rod	3
Valve Manifolds	22	Wrist Type High Voltage Alarm	
Valve Pipe Fittings & Piping System	34	Model KM-HVW-289	6
Valves	26	<b>Z</b>	
Variable Displacement Vane Pumps	31	Zinc Sulphate	38

## A D V E R T I S E R S ' I N D E X

<b>A</b>		<b>M</b>	
Arbuda Instruments	11	Masyc Projects Pvt Ltd	c-iii
<b>C</b>		Mec Shot Blasting Equipments Pvt Ltd	c-i
C. Bole & Co.	17	Moldex Corporation	4
<b>D</b>		<b>N</b>	
Del Pd Pumps & Gears (P) Ltd	c-iv	Nirmal Energy Limited	4
<b>E</b>		<b>R</b>	
Empire Cable Industries Pvt Ltd	c-ii	R. K. Dutt Concerns	c-i
<b>F</b>		<b>T</b>	
Fitzer Instruments Company (India)	13	Toshniwal Instruments (Madras) Pvt Ltd	7
<b>I</b>		<b>V</b>	
INTEC 2024	9	Ventura Alloy and Steels Private Limited	3
<b>K</b>		Vijayalaxmi Enterprises	c-i
K. U. Sodalamuthu and Co. Pvt Ltd	5		

# BULK MATERIAL HANDLING SYSTEMS PRODUCT RANGE



PIPE CONVEYORS



PULSE JET BAG FILTER



IMPACT HAMMER CRUSHER

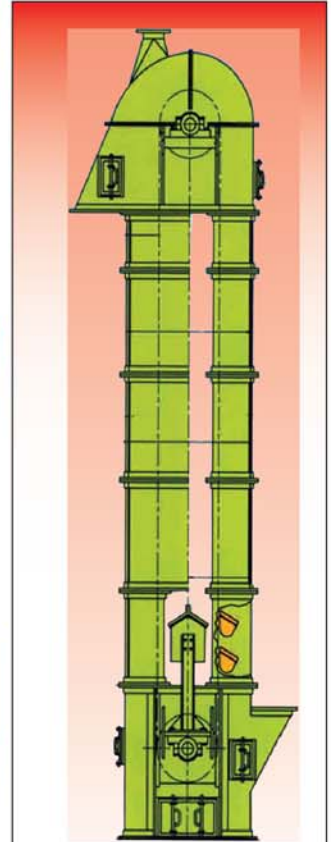

HEAVY DUTY BUCKET ELEVATOR



VIBRATING GRIZZLY FEEDER / VIBRATING FEEDER



BELT CONVEYORS



AUTOMATED REFERENCE METHOD SAMPLER



RESONANCE SCREEN

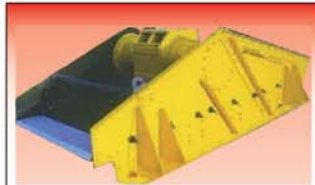

BRUTE FORCE SCREEN



HIGH FREQUENCY SCREEN

## Quality Policy

To be Customer's Delight and achieve all round excellence.  
To Strive for continuous improvement in business performance through  
Commitment of all Employees.

Bulk Material Handling Systems



# MASYC

AN ISO 9001 : 2008 CERTIFIED COMPANY



ISO 9001:2008 Indian Association of Engineers and Technicians

## MASYC PROJECTS PVT. LTD.

23, Community Centre, Mayapuri Phase-1, New Delhi 110 064 (INDIA)

Tel: 11 2811 5745, 2811 5453, 2811 3383

E-mail: [masyc@masycproject.com](mailto:masyc@masycproject.com), Website: [masycproject.com](http://masycproject.com)

**We Also Undertake Turnkey Execution of Cement Grinding Units**

So Ask For, Go For & Insist For World Class



Rotary Gear, Twin Gear, Triple Twin Gear Pump

We Generate Electric Power Through our Gear Pump Business.  
Strange & Surprising ! but a Proven Fact  
Since Power Saved is Electricity Generated

**Type ET**



Rotary Tricoidal Pump  
From 1/2" x 1/2"  
10 LPM to 120 LPM  
Pressure upto 8 kg/cm<sup>2</sup>  
App: Fuel oil, Lube oil, Eng oil.

**Type HGMX**



Rotary Gear Pump  
From 1/8" To 2 1/2" NPT  
5.0 LPM to 350 LPM  
Pressure upto 10 kg/cm<sup>2</sup>  
App: Oil, Castor oil, Gear oil,  
Resin, etc.

**Type RDRN / RDRX**



Rotary Twin Gear Pump  
From 1/2" to 4" NB  
(Flanged to ASA 150 Class)  
Capacity upto 200 M<sup>3</sup>/hr  
Pressure upto 11 kg/cm<sup>2</sup>  
App: FO, LO, HSD, LDO, Crude oil, HFO, LSHS, etc.

**Type HGXC**



Rotary Monoblock Pump  
Lube oil priming &  
Filling pump  
Size from 1/2" To 1" BSP  
Flow upto 60 LPM  
Pressure upto 7 kg/cm<sup>2</sup>  
App: LO, Base oil, Hydr oil, Turbine oil.

**Type RDBX RDNX**



Rotary Gear Pump  
From 1/2" To 6" Size  
Flow upto 125 M<sup>3</sup>/hr  
Pressure upto 21 kg/cm<sup>2</sup>  
App: Lube oil, Fuel oil, LSHS,  
Naphta, HFS.

**Type RDMS All SS**



Rotary Gear Pump From 1/8" To 1/2" NPT  
0.75 M<sup>3</sup>/hr To 120 M<sup>3</sup>/hr Pressure upto 15 kg/cm<sup>2</sup>  
App: Foam, Chemicals, Paints, Varnish-  
molasses, Resin, Soap solution.

**Type HGXS All SS**



Rotary Gear SS Pump From 1/8" To 2 1/2" NPT  
Flow From 5.0 LPM To 350 LPM Pressure upto 10 kg/cm<sup>2</sup>  
App: Glycerine, DYE, Glucose, Sugar syndp,  
Clean, Glue, Glycol.

**Type SPN**



Rotary Gear Pump  
From 1/8" To 5/8" NB  
5 LPM to 235 LPM  
Pressure upto 20 kg/cm<sup>2</sup>  
App: Lube oil, Fuel oil, Hydr oil, Turbine oil.

**Type NDX**



Rotary Tripple Twin Gear Pump  
Size From 5" To 12" NB  
Cap : 80M<sup>3</sup>/hr To 550 M<sup>3</sup>/hr  
Pressure upto 11 kg/cm<sup>2</sup>  
App: Bulk cargo load/UL  
Fuel oil, LO, Crude oil, HSD, LDO, Gas oil, etc.

**Type HGBX**



Rotary Gear Pump  
Size From 1/4" To 2 1/2" BSP  
Capacity From  
2.5 LPM To 400 LPM  
Pressure upto 10 kg/cm<sup>2</sup>  
App: FO, LSHS, LO, HFO, Tran oil.

**Type RDRBJ**



Rotary Jacketed Pump  
From 1/8" To 1/2" NB  
Upto 200 M<sup>3</sup>/hr  
Pressure upto 11 kg/cm<sup>2</sup>  
App: Bitumen, Tar, Asphalt,  
Silicel, Wax, Grease.

**Type RDRBF**



Rotary Main Oil Pump  
From 1/8" To 1/2" NB  
Upto 200 M<sup>3</sup>/hr  
Pressure upto 11 kg/cm<sup>2</sup>  
App: Lube oil, Turbine oil,  
Hyd oil, Engine oil

APPROVED BY : EIL,UHDE,DALAL,AKER,TOYO,TECHNIMONT,LURGI,TECHNIP,DGQA,DLW,DMW,BVQI,DNV,IRS,ABS,LLOYDS,MOODY.



**Del Pd Pumps & Gears (P) Ltd.**

113,G.I.D.C., Estate, Wadhwan- 363035 SurendraNagar, Gujarat (India)

Phone :+91-2752-243047 / 243678 / 241223 Fax : 91-2752-243744

Email :rotodel\_ad1@sanchainet.in , sales@delpump.com

Website : www.delpump.com